

Best Practice in Steel Construction

RESIDENTIAL BUILDINGS

Guidance for Architects, Designers & Constructors



Contents



The Steel Construction Institute (SCI) develops and promotes the effective use of steel in construction. It is an independent, membership based organisation. SCI's research and development activities cover multi-storey structures, industrial buildings, bridges, civil engineering and offshore engineering. Activities encompass design guidance on structural steel, light steel and stainless steels, dynamic performance, fire engineering, sustainable construction, architectural design, building physics (acoustic and thermal performance), value engineering, and information technology.

www.steel-sci.org

This publication presents best practice for the design of steel construction technologies used in residential buildings, and is aimed at architects and other members of the design team in the early stages of planning a residential building project. It was prepared as one of a series of three under an RFCS dissemination project Euro-Build in Steel (Project n° RFS2-CT-2007-00029). The project's objective is to present design information on best practice in steel, and to take a forward look at the next generation of steel buildings. The other publications cover best design practice in commercial and residential buildings.

The Euro-Build project partners are:

- ArcelorMittal
- Bouwen met Staal
- Centre Technique Industriel de la Construction Métallique (CTICM)
- Forschungsvereinigung Stahlanwendung (FOSTA)
- Labein Tecnalia
- SBI
- The Steel Construction Institute (SCI)
- Technische Universität Dortmund

Although care has been taken to ensure, to the best of our knowledge, that all data and information contained herein are accurate to the extent that they relate to either matters of fact or accepted practice or matters of opinion at the time of publication, the partners in the Euro-Build project and the reviewers assume no responsibility for any errors in or misinterpretations of such data and/or information or any loss or damage arising from or related to their use.

ISBN 978-1-85942-001-0

© 2008. The Steel Construction Institute.

This project was carried out with financial support from the European Commission's Research Fund for Coal and Steel.

Front cover: Liljeholmstorget (Stockholm, Sweden). Photograph by JM AB.

01 Introduction



02 Key Design Factors



03 Floor Systems



04 Wall Systems



05 Primary Steel Frames



06 Modular Systems



07 Façade & Roof Systems



08 National Practice



09 Case Studies



01 Introduction

The design of housing and residential buildings is influenced by many factors, including new requirements for sustainability, and thermal and acoustic performance. The environmental need to conserve land use, whilst improving the social characteristics of the built environment, also have a direct effect on the choice of constructional system. The pressure for more efficient and sustainable construction processes to meet these challenges has led to a demand for higher degrees of prefabrication and improved quality in the performance of the chosen construction technology.

Steel constructional technologies have achieved a high market share in other building sectors and the same technologies can be used in housing and residential buildings, where the main benefits include: speed of construction, higher levels of quality, reliability and longevity, and the ability to provide more adaptable use of space.

This publication presents best practice for the range of steel technologies used in housing and in residential buildings of all types, including mixed use commercial and residential buildings.

The steel technologies may be used separately or in combination to provide complete building systems. These 'hybrid' forms of construction technologies lead to a wide variety of design solutions.

The guidance covers structural and building physics aspects of these steel technologies. Differences in national practices are also identified and the constructional technologies are illustrated by a series of case examples of recent housing and residential projects in four countries.



*Figure 1.1 3 storey terraced housing using light steel framing (Basingstoke, UK)
HTA Architects*

02 Key Design Factors

The design of housing and residential buildings is influenced by many factors. The following general guidance is presented to identify the key design factors and the benefits of steel construction in this sector.

Housing & Residential Building Market

New house building accounts for less than 1% of the total housing stock across Europe, but this sector of construction is the focus for improvements in performance and greater concern for sustainability in social, economic and environmental terms. Residential buildings are responsible for 27% of all CO₂ emissions across the EU and therefore are targeted for improvements in energy efficiency. The renovation of housing, including extending and adapting existing buildings, represents a significant additional market.

There are important trends affecting the housing and residential building sector that are similar across Europe:

- Improved levels of thermal insulation and incorporation of renewable energy technologies to reduce primary energy use in this sector.
- Building to higher densities, particularly in urban locations, or on former industrial sites, in order to conserve land use.
- Building faster with less disruption and to higher quality, using prefabricated construction techniques.
- Reducing building costs and long-term operational costs.
- Increasing extent of single person and old person accommodation, reflecting changes in social patterns.
- Provision of buildings that are adaptable to a range of uses, and change of use in the longer term.

Steel construction systems are well placed to respond to these trends, particularly when using prefabricated technologies and in the medium to high-rise residential building sector, where speed of construction is more important.

Increasingly, there is a trend towards mixed use buildings which may involve commercial, social and residential parts to create a 'live, work, play' environment. Long-term flexibility in use and future adaptability is important in many building types.

In housing, three storeys rather than two storeys are increasingly preferred in urban locations in order to minimise the building 'footprint' and land use. An additional floor can be provided by efficient use of the roof space, which can be more readily achieved with open roof systems in steel. Kitchens and bathrooms can be produced as modular components in order to optimise the speed of construction and economy of scale in manufacture.

Sustainability

Environmental and sustainability issues dominate the design of new housing and residential buildings. Various national requirements exist for thermal performance and sustainability, which are embodied in national Regulations. These general sustainability issues may be characterised by specific requirements to:

- Reduce primary energy use and hence CO₂ emissions.
- Minimise materials use and waste, and maximise recycling of waste in construction.

Housing and Residential Building Market

Sustainability

Speed of Construction

Long-term Use

Acoustic Insulation

Fire Safety

Thermal performance

Loading

Figure 2.1 Apartment building in Helsinki showing use of integral balconies
Kahri Architects



- Use water efficiently and make provision for recycling of 'grey' water.
- Eliminate pollution and protect the local environment.
- Design of attractive public space and improved health and wellbeing in the building environment.

Steel technologies score well in terms of these sustainability issues. For example, steel is 100% recyclable and the small amount of waste that is created in manufacture and construction is recycled. All steel construction systems can be re-used or recycled at the end of their life.

Prefabrication of steel components increases site productivity and speed of construction by up to 70%, and reduces the disruption to the locality during the construction process. Using steel construction, more adaptable space can be created, which leads to long life buildings that can serve a number of functions and future uses.

Speed of Construction

A characteristic of all steel technologies is their speed of construction on site and improved productivity through efficient

construction using prefabricated systems. Studies have shown that 2 dimensional or panelised systems are 30 to 40% faster to build than masonry construction, for example, and that fully modular systems are 60 to 70% faster than these more traditional methods.

The financial benefits of speed of construction are:

- Reduced site facilities and management costs.
- Early return on the client's investment.
- Reduced interest costs during the construction period.

These benefits lead to reduced cash flow and higher return on capital.

Speed of construction is particularly important for larger residential buildings and for buildings such as student residences, which must be completed to meet the academic year.

Long-term Use

The design life of housing and residential buildings is typically 60 years in terms of the primary structure and building

envelope. However, buildings must be flexible in use and adaptable to future demands, which steel technologies can achieve through use of re-locatable partitions, longer span floors and use of 'open' roof systems.

Galvanised steel components are durable and long lasting, as shown by measurements of buildings in different climatic conditions. A design life of over 100 years is predicted for steel components contained within the building envelope.

Acoustic Insulation

Effective acoustic insulation of separating walls and floors between living spaces is very important to the health and wellbeing of the building occupants. For transmission of airborne sound, the acoustic performance is characterised by a sound reduction index ($D_{nT,w}$ in dB) between rooms, based on a standard test to EN ISO 717-1, which covers a range of frequencies over 16 one third octave bands from 100 to 3150 Hz. For impact sound, which only applies to floors, the sound transmission $L_{t,w}$ across a floor due to a standard tapping machine should not exceed a maximum value.



Figure 2.2 16-storey student residence constructed using a primary steel frame and light steel infill walls (Southampton, UK)



Figure 2.3 Steel-framed apartment building in Evreux, France with light steel walls and floor decking and lightweight cladding Architects: Dubosc & Landowski

| Loading Type | Typical Value (kN/m ²) |
|------------------------------|------------------------------------|
| Imposed loads: | |
| Residential use | 1.5 to 2.0 |
| Corridors and communal areas | 3 |
| Commercial areas | 2.5 to 4 |
| Partitions (lightweight) | 0.5 to 1.0 |
| Self weights: | |
| Light steel walls | 0.5 to 1.0 |
| Light steel floors | 0.7 |
| Lightweight roofs | 0.5 |
| Tiled roofs | 0.9 |
| Structural steel frame | 0.3 to 0.5 |
| Composite floor slabs | 2.5 to 3.5 |
| Precast concrete slabs | 2.5 to 4 |

Table 2.1 Typical loads used in housing and residential buildings

For acceptable acoustic performance, the minimum airborne sound reduction is 45 dB for walls and floors between separate living spaces. This performance parameter is verified by test measurements of completed buildings which also take account of local acoustic transmission through junctions, such as at floor to wall junctions.

Fire Safety

Fire safety in residential buildings covers a range of factors such as: effective means of escape in fire, prevention of fire spread, structural stability, and the provision of effective fire fighting measures. Requirements for structural stability and compartmentation are usually expressed as the 'fire resistance' of the structural elements.

Fire resistance is based for calibration purposes on the results of standard fire tests and is expressed in units of 30 minutes. For most housing and residential buildings, a minimum fire resistance of 30 minutes is required, increasing to 60 minutes for separating walls, dependant on national regulations.

Taller buildings may require 90 minutes fire resistance primarily for reasons of structural stability and effective fire fighting. Generally, for walls and floors, the measures introduced to achieve satisfactory acoustic insulation also achieve at least 60 minutes fire resistance.

Thermal Performance

One of the most effective ways of reducing primary energy consumption is by improved thermal performance of the building envelope, such as by reducing thermal transmission and improving air tightness. Thermal insulation of the building envelope is characterised by its U-value, which represents the heat loss through a unit area of the external elements of the façade or roof per degree temperature difference between inside and outside.

A U-value of 0.3 W/m²K is generally adopted as a maximum value for façade elements of the building envelope, and a U-value of 0.2 W/m²K is generally adopted as the maximum for roofs (depending on the country).

This can be achieved by using insulation placed externally to the light steel walls and roof so that the risk of cold bridging and condensation is minimised. One innovation is to use perforated or slotted light steel sections to reduce cold bridging effects. Most of the insulation can be placed efficiently between the light steel components and leads to a reduction in wall thickness.

Loading

The principal types of loading to be considered in the design of housing and residential buildings are:

- Self weight (including finishes).
- Imposed loads (including higher loads in communal areas).
- Wind actions.
- Snow loads (or roofs).

Typical loads are presented in Table 2.1. Steel-framed buildings are much lighter than concrete or masonry buildings and save on foundation costs.

03 Floor Systems

This section describes the main floor systems used in housing and residential buildings. The characteristics of each floor system are described together with guidance on the important design issues.

Floors may span between load-bearing light steel walls, or may be supported by steel beams in a primary steel frame.

There are three generic forms of floors considered in this guide:

- Light steel floors.
- Composite floor slabs.
- Deep composite slabs.

Light steel floors are usually of C shape, although they can be of lattice form for longer spans. These lightweight flooring elements may be installed as individual components or as 2 dimensional panels (in the form of prefabricated floor cassettes).

Composite slabs comprise in-situ concrete placed on steel decking. Composite slabs are increasingly used in residential buildings because of their ability to provide a stiff, acoustically excellent and fire resistant construction. The steel beams are normally designed to act compositely with the slab, but in some cases, composite slabs are supported directly by light steel walls.

Deep composite slabs may be of various forms using deeper deck profiles to create an overall floor depth of typically 300 mm. Beams may be integrated into the slab depth and there are no downstand beams - see Section 4.

Light Steel Floor Joists

Composite Floor Slabs

Deep Composite Slabs



Figure 3.1 Floor systems using light steel joists supported on light steel walls
Fusion Building Systems

Light Steel Floor Joists

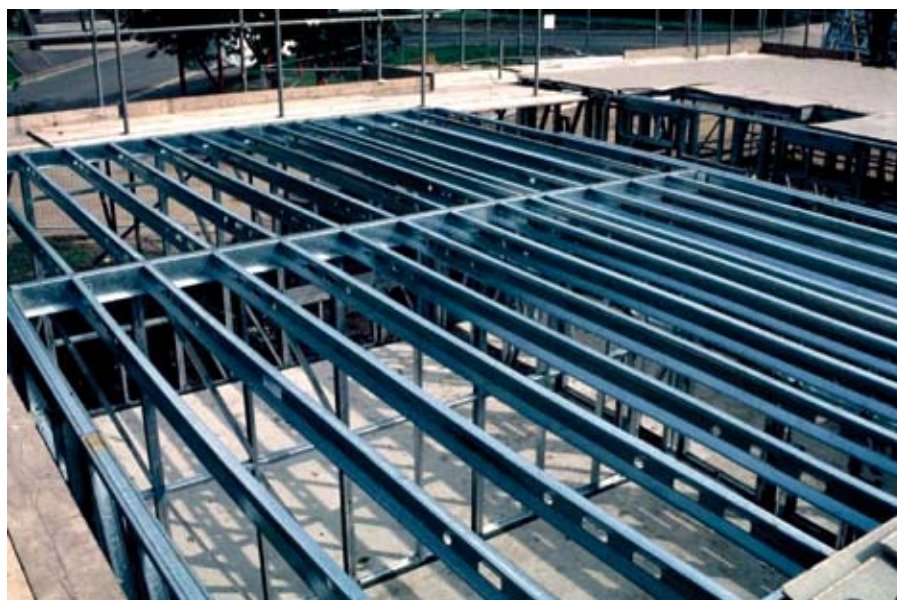

Figure 3.2 Light steel floor joists supported on Z sections positioned over load-bearing light steel walls

Description

C section joists are typically 150 to 300 mm deep and are manufactured in steel thicknesses of 1.6 to 2.4 mm using S280 to S390 galvanised steel to EN 10326 (with G275 or 40 microns total zinc coating). Lattice joists are typically 300 to 500 mm deep and permit services of up to 100 mm diameter to be passed between the bracing members. Joists are typically placed at 400 mm to 600 mm spacing to align with ceiling and floor board spans and dimensions.

The floor joists are attached directly to the supporting elements or supported on Z sections that are placed over beams or walls, so that flexibility in positioning the joists is provided, as shown in Figure 3.2. When manufactured as 2 D cassettes, special attachment points are often introduced to connect the floors to the walls.

Gypsum-based screeds can be placed on the flooring to improve its stiffness and acoustic insulation. Steel decking can be used to replace floor boarding and achieve composite action with the joists. This form of construction is shown in Figure 3.3.

For longer span areas, hot rolled or fabricated steel beams may be introduced to support the joists. These beams may be integrated in the floor depth by supporting the joists on the bottom flange of the beams, as shown in Figure 3.4.

Main Design Considerations

Floor joists support floor boards above and plasterboard below, which are of sufficient thickness to achieve both good acoustic insulation and fire resistance. These requirements often lead to the use of 2 or 3 layers of plasterboard in the ceiling and mineral wool or glass wool is placed between the joists. In bathrooms and kitchens, a separate servicing zone may be required below the floor, which can require use of a suspended ceiling.

The light weight of these floors means that sensitivity to floor vibrations is important; the design needs to ensure that resonant effects do not occur due to walking and other normal activities. A minimum natural frequency of 8 Hz is generally adopted for lightweight floors to minimise the effect of rapid walking and other impacts on vibrations.



Figure 3.3 Lattice joists supporting gypsum screed used in long span floors
Metek Building Systems



Figure 3.4 Light steel floor joists supported on steel hot rolled beams
Ruukki

Advantages

- Easy to install on site.
- Boards attached to the joists provide acoustic insulation and fire resistance.
- Wide availability of different joist sizes.
- Floor cassettes may be manufactured and installed as larger components.

Fire Resistance

Fire resistance is achieved by two or three layers of fire resisting plasterboard (Type F boards to EN 520). The measures introduced for effective acoustic insulation generally achieve 60 minutes fire resistance. A fire resistance of 60 minutes is provided by 2 layers of 12 mm fire resisting plasterboard below the floor joists.

Acoustic Insulation

A high level of acoustic insulation is achieved using the details shown in Figure 3.5, which avoid acoustic losses at the floor-wall junctions. Various types of resilient floor covering and mineral wool placed between the joists reduce sound transmission.

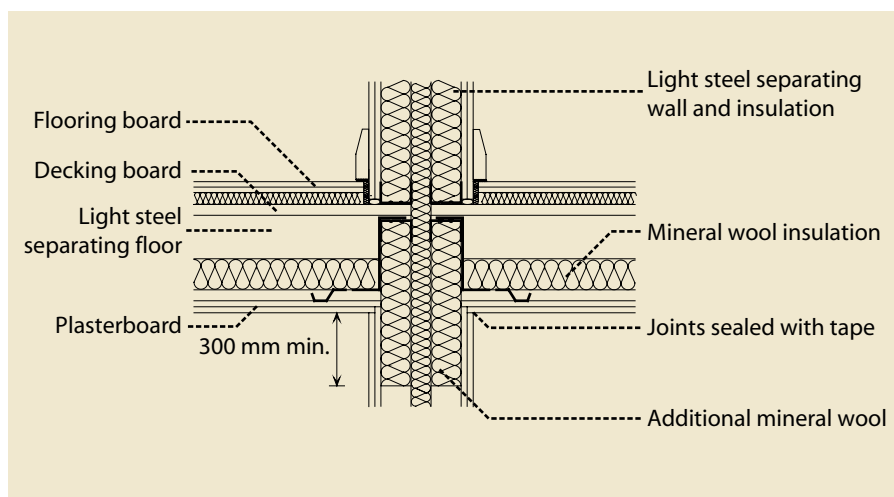

Figure 3.5 Acoustic build up of light steel floor and its detail at a separating wall

Loads and Deflections

Light steel joists support imposed loads typically up to 3 kN/m² for spans of 3 to 6 m (Table 3.1). Deflections should be limited to the following maximum values so that movements are not visible and to minimise perceptible floor vibrations:

- Span/350, or a maximum of 15 mm under self weight plus imposed load (characteristic values).
- Span/450 under imposed load alone.
- Local deflection of less than 1.5 mm under a 1 kN point load, using an effective spread of the point load onto the joists.

The deflection limit of 15 mm ensures that the floor achieves the 8 Hz natural frequency limit, and leads to the maximum spans given in Table 3.1.

Overall Floor Zone

The overall floor zone of a light steel joisted floor, including acoustic layers and a plasterboard ceiling, is typically:

- 300 mm for floor spans up to 3.8 m;
- 400 mm for floor spans up to 4.8 m;
- 500 mm for floor spans up to 6 m.

| Floor joists | Joist spacing (mm) | Max. span in housing (m) | Max. span in apartments (m) |
|--|--------------------|--------------------------|-----------------------------|
| 150 x 1.6 C | 400 | 3.8 | 3.6 |
| 200 x 1.6 C | 400 | 4.8 | 4.5 |
| 200 x 2.0 C | 400 | 5.2 | 4.8 |
| 250 mm lattice joists | 400 | 5.0 | 4.8 |
| 300 mm lattice joists | 400 | 5.5 | 5.2 |
| 300 mm lattice joists with 40 mm gypsum screed | 600 | 6.0 | 5.7 |

Housing: Imposed loads = 1.5 kN/m² Self weight = 0.5 kN/m²
Apartments: Imposed loads = 2.5 kN/m² Self weight = 0.7 kN/m² (1.7 kN/m² inc. gypsum screed)

Table 3.1 Typical floor joist spans in housing and residential buildings

Composite Floor Slabs



Figure 3.6 Typical composite slab and composite steel edge beams
Kingspan

Description

Composite floor slabs comprise in-situ concrete placed on steel decking, as illustrated in Figure 3.6. Spans of 2.5 to 4.5 m can be achieved by composite floors using steel decking of 50 to 80 mm depth with steel thicknesses of 0.8 to 1.2 mm. No temporary propping is required during construction, provided the deck depth is carefully chosen for the required span.

A composite slab is typically 120 to 160 mm deep and is reinforced by mesh (such as A142 to A193, defined by the reinforcement area (in mm^2/m)). In some cases, additional bars are placed in the rib of the decking to improve the bending resistance and fire resistance of the slab. However, 90 minutes fire resistance can be achieved by use of nominal mesh reinforcement of 0.2% of the cross sectional area of the slab.

Main Design Considerations

Composite slabs are relatively shallow with respect to their span (ratios of span: depth of up to 32 are possible). However, it is the span capabilities of the steel decking in unpropped construction that controls the design.

For most applications, support from secondary beams or load-bearing walls is required at spans of approximately:

- 3 m for deck profiles of 50 mm depth;
- 3.6 m for deck profiles of 60 mm depth;
- 4.2 m for deck profiles of 80 mm depth.

Design tables for composite slabs are presented in Table 3.2. Longer spans can be achieved in propped construction provided the supporting floor is capable of resisting the prop loads. Optimum design is achieved when the decking is placed continuously over one or more internal supports.

Advantages

- Stiff, robust form of construction.
- Wide range of deck profiles and steel thicknesses for optimum design.
- No temporary propping is required for most applications.
- Good acoustic insulation and fire resistance.

| | |
|-----------------------------|--|
| Fire Resistance | The effective slab depth influences the insulation that is provided in fire conditions, and so deeper slabs are required for longer fire resistance periods. The amount of reinforcement also increases with fire resistance, as its effectiveness reduces with temperature. Span and load capabilities for various slab depths and fire resistance periods for composite slabs of 120 to 150 mm depth are presented in Table 3.2. |
| Acoustic Insulation | Composite floors with plasterboard ceilings can achieve excellent sound reductions of over 60 dB. |
| Load and Deflections | Load span guidance is presented in Table 3.2. In residential buildings, 80 mm deep deck profiles used in slabs of 150 mm depth can span 4.5 m without temporary propping, which is ideal for internal space planning. Deflections under imposed load are limited to span/360, but deflections of the underside of the decking after concreting can be as high as span/180. |
| Overall Floor Zone | The overall floor zone of a composite floor can be as low as 250 mm allowing for acoustic layers and plasterboard ceiling, but increases due to the beam depth where steel support beams do not align with walls. In other cases where beams do not align with walls, an overall floor depth of 600 mm may be used in planning. |

| Span Case | Fire resistance (mins) | Slab depth (mm) | Reinforcement (mm ² /m) | Maximum spans (m) for imposed loading | | | |
|--------------------------------|------------------------|-----------------|------------------------------------|---------------------------------------|-----------------------|-----------------------|-----------------------|
| | | | | t = 0.9 mm | | t = 1.2 mm | |
| | | | | 3.5 kN/m ² | 5.0 kN/m ² | 3.5 kN/m ² | 5.0 kN/m ² |
| Single span decking - no props | 60 | 120 | A142 | 2.8 | 2.8 | 3.2 | 3.2 |
| | 90 | 130 | A193 | 2.7 | 2.7 | 3.1 | 3.0 |
| Double span decking - no props | 60 | 120 | A142 | 3.2 | 3.2 | 3.9 | 3.7 |
| | 90 | 130 | A193 | 3.1 | 3.1 | 3.8 | 3.5 |
| | 120 | 150 | A252 | 2.9 | 2.9 | 3.5 | 3.4 |
| One line of temporary props | 60 | 120 | A353* | 3.8 | 3.4 | 4.0 | 3.6 |
| | 90 | 130 | A353* | 3.4 | 3.1 | 3.6 | 3.3 |
| | 120 | 150 | A353* | 3.1 | 2.9 | 3.3 | 3.0 |

t = steel thickness of decking *required for crack control in propped construction A193 = 193mm²/m reinforcement in both directions

(a) 60 mm deep decking

| Span Case | Fire resistance (mins) | Slab depth (mm) | Reinforcement (mm ² /m) | Maximum spans (m) for imposed loading | | | |
|--------------------------------|------------------------|-----------------|------------------------------------|---------------------------------------|-----------------------|-----------------------|-----------------------|
| | | | | t = 0.9 mm | | t = 1.2 mm | |
| | | | | 3.5 kN/m ² | 5.0 kN/m ² | 3.5 kN/m ² | 5.0 kN/m ² |
| Single span decking - no props | 60 | 150 | A193 | 3.7 | 3.2 | 4.1 | 3.5 |
| | 90 | 160 | A252 | 3.8 | 3.2 | 3.9 | 3.3 |
| Double span decking - no props | 60 | 150 | A193 | 4.2 | 3.8 | 4.6 | 4.1 |
| | 90 | 160 | A252 | 4.1 | 3.9 | 4.5 | 4.0 |
| | 120 | 170 | A393 | 4.0 | 3.9 | 4.3 | 3.9 |

(b) 80 mm deep decking

Table 3.2 Typical design tables for composite floors

Deep Composite Slabs



Figure 3.7 Steel frame with deep composite floor, integrated ASB beams and infill walls

Description

Deep steel decking may be designed to act compositely with a concrete slab to create an overall floor depth of typically 300 mm. Spans of up to 6 m can be achieved without requiring temporary propping. The decking profile is typically 190 to 225 mm deep, depending on the product. The minimum depth of concrete over the decking is 70 to 90 mm, depending on the fire resistance requirements.

The Corus *Slimdek* system uses either an asymmetric ASB beam or a UC/HE section with a welded bottom plate to support SD225 deep decking, as shown in Figure 3.7. This system is widely used in the residential sector in the UK and NL, see Section 8. Edge beams may be in the form of Rectangular Hollow Sections with a welded plate for visual and detailing reasons and for their improved torsional resistance.

Hoesch *Additif* is a deep decking system that uses bars welded transversely to the top flange of an IPE or HE section on which the top of the decking profile sits - see Figure 3.8. This system is often used in car parks with spans of up to 5.5 m.

The *Cofradal* system uses a steel tray with high density mineral wool onto which in-situ concrete is placed. This floor is 200 mm deep and can span up to 6 m in residential buildings (Section 8).

Main Design Considerations

Deep composite slabs can span long distances and the main design consideration is the ability of the decking to support the loads during construction without requiring temporary propping. Typically unpropped spans are as follows:

- 225 mm deep decking – 6 m span for a slab depth of 300 mm;
- 190 mm deep decking – 5.4 m span for a slab depth of 270 mm.

Additional reinforcement is required for fire resistance. Spans up to 9 m can be achieved in propped construction. For acceptable serviceability performance, span to slab depth ratios of 25 are possible with suitable reinforcement.

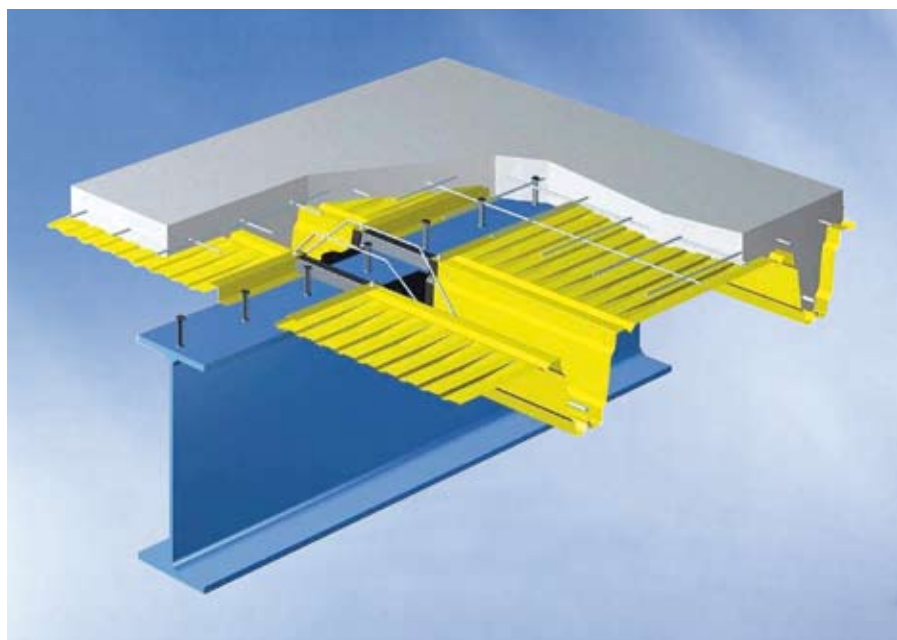

Figure 3.8 Illustration of Hoesch Additif flooring system supported by steel beams

Advantages

- Stiff, robust form of construction.
- Long spans (up to 6 m in unpropped construction).
- Good acoustic insulation and fire resistance.
- Shallow floor when combined with slim floor or integrated beams.
- Freedom in internal space planning.

Fire Resistance

For fire resistance, the following minimum requirements may be used in the scheme design of deep composite slabs with reinforcement in the deck ribs:

| Fire resistance (mins) | Minimum slab depth over decking | Minimum reinforcement per rib | Minimum reinforcement in slab |
|------------------------|---------------------------------|-------------------------------|-------------------------------|
| 30 | 60 mm | 12 mm dia. | A142 |
| 60 | 70 mm | 16 mm dia. | A193 |
| 90 | 90 mm | 20 mm dia. | A252 |

A193 = 193 mm²/m reinforcement in both directions

Table 3.3 Fire resistance requirements for deep composite slabs

Acoustic Insulation

Deep composite slabs achieve excellent sound reductions of over 60 dB. Special details are required at junctions between floors and walls.

Overall Floor Zone

The overall floor zone is typically 400 to 500 mm with acoustic layers and suspended ceiling. The use of integrated or slim floor beams means that internal walls can be placed anywhere on the plan without being affected by downstand beams.

04 Wall Systems

This section describes the various forms of external and internal walls using light steel framing. The characteristics of each wall system are described together with guidance on the important design issues. The thermal performance of cladding systems is presented in Section 7.

Walls may be designed in light steel framing as part of a load-bearing structure or as non-load-bearing elements within a primary steel frame. There are three generic forms of walls in light steel framing:

- Load-bearing walls.
- Infill walls which support the façade.
- Separating walls and partitions.

Load-bearing light steel walls may be used to support light steel floors using C section joists or floor cassettes.

Alternatively, composite slabs may be supported by a perimeter C section. Load-bearing light steel walls have been used in buildings up to 8 storeys high.

Infill walls are used in a primary steel or concrete structure and are designed to support the cladding and to resist wind loads. They may be prefabricated or installed as individual C sections.

This same technology may be used for internal separating walls.

Load-bearing Light Steel Framing

External Infill Walls in Structural Frames

Separating Walls and Partitions



Figure 4.1 Installation of light steel infill wall in a steel frame
Kingspan Architectural

Load-bearing Light Steel Framing



Figure 4.2 Platform construction of braced light steel wall in housing
Fusion Building Systems

Description

Load-bearing walls in light steel framing use C sections of 70 to 150 mm depth and steel thicknesses of 1.6 to 2.4 mm, manufactured into two dimensional wall panels. The most common form of construction is known as 'platform' construction in which the walls are installed using the floors as a working platform. The use of braced wall panels is shown in Figure 4.2. Forces are transferred directly through the walls and the floors are typically supported by a Z section placed over the lower wall.

Wall studs (vertical C sections) are placed at 300, 400 or 600 mm spacing to align with standard plasterboard widths of 1.2 or 2.4 m. Generally, within a wall panel, the same thickness of C section is used, although multiple C sections can be detailed next to large openings or other highly loaded areas. Double layer separating walls are preferred but in some cases, single layer walls may be used, provided that services do not penetrate the wall.

Load-bearing light steel walls are usually one of three generic forms:

- Double layer walls comprising mineral wool or glass wool insulation placed between the C sections and two plasterboard layers placed on the outer faces of the wall.
- Double layer walls, as above, but with rigid insulation board placed between the layers.
- Single layer walls using a minimum of 100 mm deep C sections with 'resilient bars' fixed to the outer face of the C section and mineral wool between the C sections and two plasterboard layers (fastened to the resilient bars).

These forms of construction are illustrated in Figure 4.3. Double layer walls are used mainly in separating walls and a total thickness of 300 mm may be used for these walls in scheme design. In other cases, single layer walls may be used and their thickness is as low as 150 mm.

| Wall C section (Depth x width x thickness) | Effective height of wall (m) | Cross-sectional resistance | | Buckling resistance (kN) | Reduced buckling resistance allowing for eccentricity (kN) |
|--|------------------------------------|--------------------------------|---|--------------------------------|---|
| | | Bending resistance (kNm) | Compression resistance - no buckling (kN) | | |
| 70 x 45 x 1.2 | 2.5 | 1.4 | 58 | 32 | 18 |
| 70 x 45 x 1.2 | 3.0 | | | 24 | 15 |
| 100 x 45 x 1.6 | 2.5 | 3.1 | 89 | 53 | 29 |
| 100 x 45 x 1.6 | 3.0 | | | 40 | 24 |

Note: Reduced buckling resistances in this Table allow for the effect of the eccentricity of the axial force acting at the face of the C section.

Table 4.1 Typical manufacturer's data giving compression resistance of load-bearing wall studs using C sections

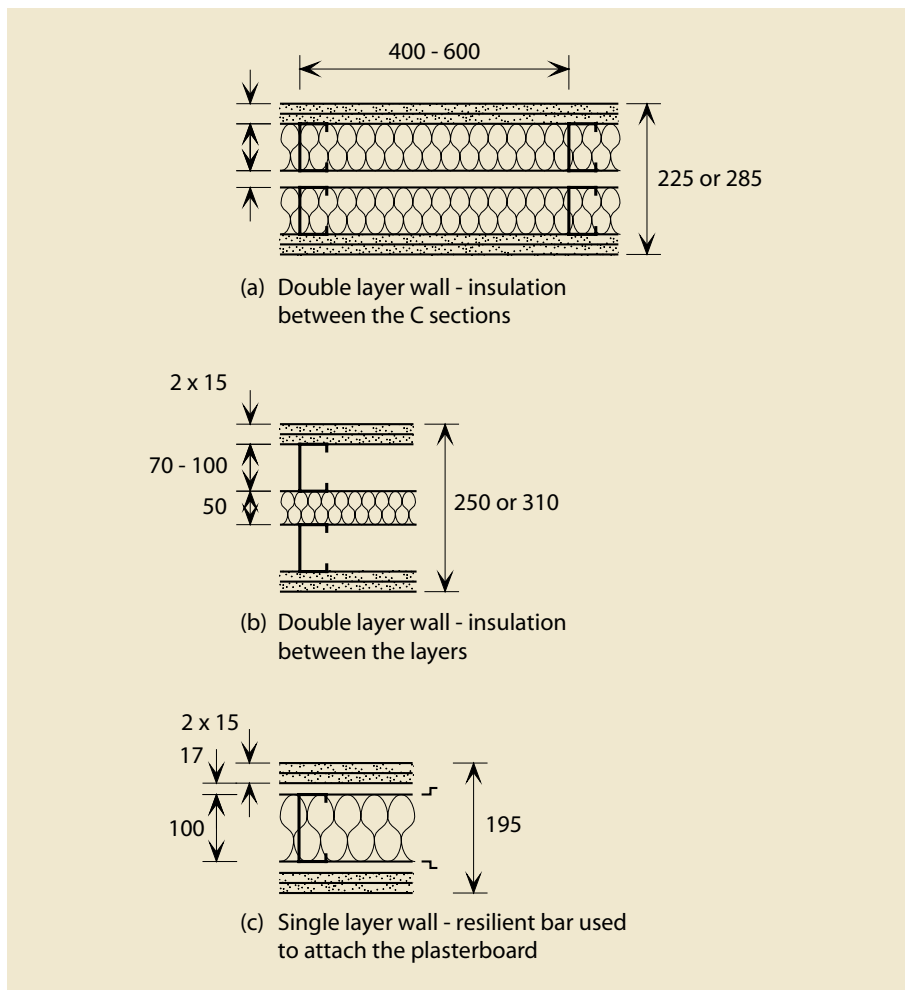

Figure 4.3 Various forms of light steel load-bearing walls

Main Design Considerations

Load-bearing walls in light steel structures are designed for combined compression and bending due to eccentric loading transferred from the floors. For multi-storey applications, 100 mm deep x 1.6 mm thick C sections are generally sufficient when placed at 300 to 600 mm spacing, but for 2 storey housing, smaller 70 x 1.2 mm C sections may be used.

The compression resistance of walls using C sections is dependent on their buckling resistance, as modified for the eccentricity of axial force and for the stabilising effect of boards attached to them. For most C sections, compression resistance is governed by major axis buckling; buckling about the minor axis is restrained by mid-height bracing or by attachment to facing boards. Data for the compression resistance of C section studs are presented in Table 4.1. Where vertical forces are applied at an eccentricity to the wall (e.g. for floors supported on a Z section placed over the wall panels), a reduction factor is made in Table 4.1 to account for combined bending and compression.

To resist horizontal forces, walls can be braced by various methods:

- Integral K or W bracing using C sections acting in tension or compression.
- External X bracing using flat steel strips acting in tension.
- Diaphragm action of wall boards, such as plywood or cement particle boards.

Generally, X bracing is most efficient for taller buildings and shear forces of up to 20 kN can be resisted by a 2.4 m square X braced wall panel.

Various forms of cladding can be attached through external insulation used to create a 'warm frame', as illustrated in Section 7. Open roof structures can be manufactured using adaptations of this technology.

Advantages

- Wall panels can be manufactured to suit any wall size and loading.
- Large openings can be provided for windows.
- Smaller wall panels (typically 2.4 m square) can be lifted manually.
- Large wall panels can be lifted mechanically, reducing installation time.
- Bracing can be installed during manufacture of the walls.
- Lightweight construction with no wastage of materials.

Fire Resistance

The fire resistance period for load-bearing walls depends on the protection by the plasterboard. The critical temperature of load-bearing wall studs may be taken as 400°C when evaluating the fire protection strategy. It is generally found that the details required for good acoustic insulation achieve at least 60 minutes fire resistance.

Acoustic Insulation

Good airborne sound insulation of light steel walls is provided by the details shown in Figure 4.3.

External Infill Walls in Structural Frames



Figure 4.4 Light steel infill walls within a composite steel structure

Description

Non load-bearing infill walls provide support to the external envelope and are designed to resist wind forces and to support the weight of the cladding.

Infill walls are one of two generic types:

- Individual C sections (wall studs) installed on site and placed in a bottom and top 'track' attached to the top of the slab and the underside of the beam of slab.
- Prefabricated storey high wall panels that are attached externally to the structure and are connected to the columns and floors, as in Figure 4.1.

An example of light steel infill walls used in a primary steel frame is shown in Figure 4.4. Infill walls can also comprise perforated or slotted C sections, as described in Section 7, which provide higher levels of thermal insulation.

Some provision for relative movement between the wall and the primary structure is made at the top of the infill wall, depending on whether the structure is in steel or concrete. Brickwork is generally ground supported, or supported on stainless steel angles attached to the primary frame. Lightweight façades are usually attached to the infill wall and are supported by it.

Main Design Considerations

Infill walls are designed primarily for wind loading with some additional vertical load due to the self weight of the wall and its cladding. Large prefabricated panels can be designed to span horizontally between columns, as well as vertically between floors, as shown in Figure 4.4. Wind pressures are determined according to EN 1991-1-4, depending on the building location, height and orientation. South or west facing panels at the corners of the buildings are the most critical for design.

The provision for relative movement depends on the type of support, but the following minimum movements are considered reasonable for beams up to 5 m span:

- 10 mm – for steel-framed buildings or existing concrete buildings;
- 20 mm – for new concrete buildings.

The top of the wall panel is usually restrained by a bracket attached at not more than 600 mm centres to the inside face of the panel. Each bracket is designed to resist wind suction (negative) forces and allow for relative vertical movement.

Figure 4.5 Prefabricated wall panel with cladding and windows
Ruukki



Advantages

- Rapid construction system that is used with either primary steel frames or concrete frames.
- Lightweight construction, with minimum material use and no waste on site.
- Large openings can be created.
- Wall panels can be prefabricated or site installed.
- Cladding can be pre-attached in prefabricated wall systems.

Fire Resistance

The fire resistance of an external wall should be sufficient to prevent passage of smoke and flame from floor to floor. Normally, 30 or 60 minutes fire resistance is required, which is achieved by one or two layers of 12 mm thick fire resisting plasterboard. Special details are required at edge beams to allow for relative vertical movement. In some cases, the walls provide some fire protection to the edge beams.

Acoustic Insulation

The acoustic insulation requirements for external walls depend mainly on the type of cladding used. Generally, an acoustic attenuation of at least 30 dB is achieved by external walls with lightweight cladding.

Overall Wall Thickness

The overall thickness of external walls depends on the level of thermal insulation and type of cladding that is required. Guidance is presented in Section 7.

Brickwork is usually ground supported, or supported by the structural frame.

Separating Walls and Partitions



Figure 4.6 Plasterboard being attached to separating wall at X bracing

Description

Separating walls are internal walls that are required to achieve acoustic insulation between separate parts of a building or between dwellings. These walls are often also required to provide a fire compartmentation function. Separating walls can also provide a load-bearing function, as described earlier, or alternatively, are non-load-bearing walls placed within a primary steel or concrete frame.

Partitions are non-load-bearing walls that have no acoustic insulation or fire compartmentation function. Partitions can be removed without affecting the function of the building.

Light steel C sections used in separating walls and partitions are 55 to 100 mm deep in 0.55 to 1.5 mm thick steel, depending on their height and loading.

Generally, separating walls are of two forms, as illustrated in Figure 4.3:

- Double leaf walls with two layers of plasterboard directly fixed to the outer faces.
- Single leaf walls with two layers of plasterboard fixed to resilient bars that are fixed to the outer face of the C section walls.

Provision for relative movement should also be made at the top of the wall in a primary steel or concrete frame.

Main Design Considerations

Single and double leaf walls of both types achieve these levels of acoustic performance using multiple layers of boards. Installation of a partition wall at a bracing position is shown in Figure 4.6. A double leaf wall is less sensitive to acoustic losses through service penetrations than a single leaf wall.

| | |
|-------------------------------|--|
| Advantages | <ul style="list-style-type: none"> • Lightweight separating walls are fast to build. • Excellent airborne sound reduction. • All non load-bearing light steel walls are relocatable. • Minimum use of materials and minimum waste on site. • Self weight is less than 0.5 kN/m² expressed per unit floor area. |
| Fire Resistance | Non load-bearing walls that meet the acoustic performance requirements also generally achieve a fire resistance of at least 60 minutes. |
| Acoustic Insulation | Separating walls are designed for airborne sound reductions of typically 52 dB without a low frequency correction factor C_{tr} , or 45 dB with a low frequency correction factor. Suitable separating wall details are presented in Figure 4.3. |
| Overall Wall Thickness | <p>The typical thicknesses of separating walls and partitions may be taken in scheme design as:</p> <ul style="list-style-type: none"> • Double leaf separating wall: 300 mm. • Single leaf separating walls: 200 mm. • Partitions: 100 mm. |

05 Primary Steel Frames

This section describes the various forms of structural steel components that may be used in multi-storey residential buildings. The characteristics of the primary steel members are described and their combination with the floor and wall systems presented earlier.

For multi-storey residential buildings requiring open plan space, a primary steel structure is the preferred option. Various steel systems are considered in this publication:

- Steel frame with precast concrete slabs.
- Composite steel frame with a composite slab.
- Integrated beam or slim floor construction.
- Inverted steel beams, such as the *Slimline* system.

Beams in a structural steel frame are usually arranged to align with separating walls, but using integrated beams, internal walls can be located anywhere on plan and are not influenced by the depth of the downstand beams (Figure 5.1). Integrated beams may use a variety of flooring systems, including deep composite slabs, precast concrete units and light steel floor joists.

Columns use HE/UC sections or Square Hollow Sections (SHS) that are usually designed to fit within the width of a separating wall.

*Steel Frames with
Precast Concrete Slabs*

*Composite Steel Frame
with Composite Slabs*

*Integrated Beams or
Slim Floor Construction*

Inverted Steel Beams



Figure 5.1 Steel frame using ASB sections and deep decking being installed

Steel Frames with Precast Concrete Slabs



Figure 5.2 Use of precast concrete slabs placed on steel beams

Description

Precast concrete floor slabs are supported on the top flange of steel beams, and in some cases, may be designed to act compositely with the steel beams by use of shear connectors that are pre-welded to the top flange, as shown in Figure 5.2. In order to provide a suitable minimum bearing length, the width of the top flange should be at least 190 mm, which leads to use of deeper IPE/UB sections or HE/UC sections.

Precast concrete slabs may be of two forms when used with downstand beams:

- Thin solid slabs (50–100 mm thick) supporting an in-situ concrete topping and generally designed to act compositely with the steel beams. Spans are in the range of 2.5 to 4 m.
- Hollowcore slabs (150–250 mm thick), which are usually designed non compositely, but can be designed compositely with a thin concrete topping. Spans are in the range of 5 to 9 m.

Precast concrete slabs can also be used with integrated beams, as described later.

Main Design Considerations

For beams supporting precast concrete slabs, the main design consideration is that of the minimum beam width to allow for construction tolerances and, if designed compositely, for sufficient space around the shear connectors used to develop composite action. For this reason, precast slabs are generally used in long span applications using deeper or wider beams.

A concrete topping (60 mm minimum) is generally required for acoustic insulation in residential buildings, and it also assists in satisfying fire resistance and ‘robustness’ requirements through the mesh reinforcement in the topping.

| | |
|------------------------------|---|
| Advantages | <ul style="list-style-type: none"> • Long span beams and slabs. • Essentially a prefabricated construction process. • Good acoustic insulation. • Downstand beams can be aligned with separating walls. |
| Fire Resistance | <p>Precast concrete slabs can achieve up to 90 minutes fire resistance without a concrete topping or up to 120 minutes with a concrete topping and with reinforcing bars embedded in the filled hollow cores.</p> <p>Fire protection of the steel beams can be achieved by:</p> <ul style="list-style-type: none"> • Board protection. • Spray protection. • Intumescent coatings. |
| Acoustic Insulation | Precast concrete slabs with a concrete topping or screed provide excellent airborne sound reduction. |
| Loads and Deflections | <p>Steel beams supporting precast concrete slabs are relatively deep and can be designed for a span:depth ratio of approximately 18. Deflections will be within normal limits of span/360 under imposed loads.</p> <p>For scheme design, the overall floor zones given in Table 5.1 should be used for steel beams supporting precast hollowcore concrete slabs.</p> |

| Beam Span (m) | Slab Span (m) | Overall Floor Depth (mm) |
|------------------|------------------|-----------------------------|
| 6 | 6 | 600 |
| 8 | 6 | 700 |
| 8 | 8 | 800 |
| 10 | 6 | 800 |

Table 5.1 Overall floor depths for steel beams supporting hollowcore slabs

Composite Steel Frame with Composite Slabs



Figure 5.3 Composite steel decking and composite cellular beams

Description

Composite slabs are supported on the top flange of steel beams and are designed to act compositely with the beams by use of shear connectors that are generally welded through the decking as an on-site process. Composite beams are widely used in all sectors of construction and are also used in residential buildings but, in this case, spans are relatively short (5 to 9 m). Composite action greatly increases the bending resistance and stiffness of the beams.

Slab spans depend on the depth of the deck profile and whether the slab is propped during construction. Typically spans range from 3 m for 50 to 60 mm deep profiles to 4 to 4.5 m for 80 to 100 mm deep profiles (see Section 3).

Main Design Considerations

In composite construction, the main criterion is to minimise the floor depth without compromising its stiffness. For this reason, shallow HE/UC sections are often used in residential buildings to achieve spans of 5 to 9 m. Beams are contained within a suspended ceiling or are aligned with separating walls.

Generally, slabs and beams are designed as unpropped in the construction condition, which means that the deck profile has to be chosen carefully to avoid use of propping – see Table 3.2. Composite beams can be perforated for services, such as in cellular beams, as shown in Figure 5.3. Long span composite beams can be designed as a 'podium' to support a light steel structure above.

Advantages

- Stiff, relatively shallow floor.
- HE/UC sections can be used as beams to minimise the floor depth.
- Good acoustic insulation.
- Walls can be aligned with beams to minimise the floor depth.
- Long span composite beams can be designed as a podium structure over car parking.

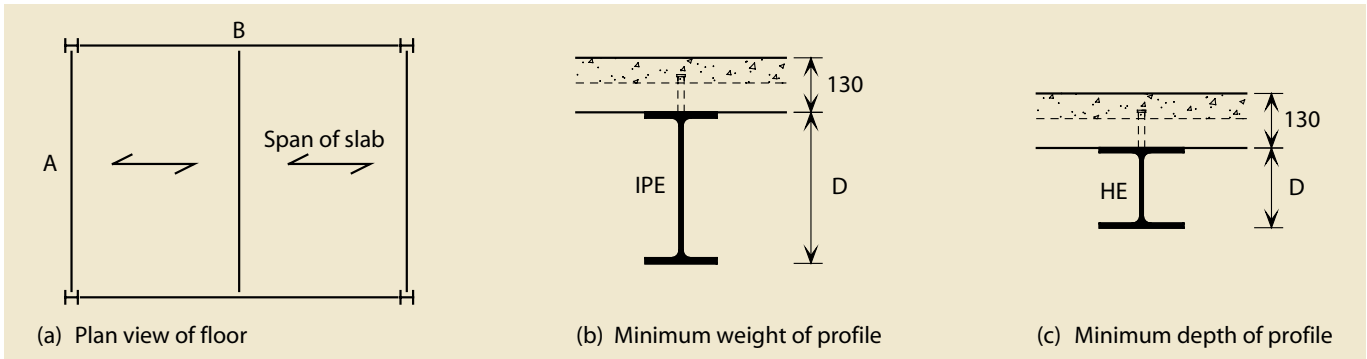

| Span of Primary Beam (B) | Span of Secondary Beam (A) | | | |
|--------------------------|----------------------------|---------|---------|---------|
| | 6 m | 8 m | 10 m | 12 m |
| 5 m | IPE 240 | IPE 300 | IPE 360 | IPE 450 |
| 6 m | IPE 240 | IPE 330 | IPE 400 | IPE 450 |
| 7 m | IPE 270 | IPE 330 | IPE 400 | IPE 500 |
| 8 m* | IPE 300 | IPE 360 | IPE 450 | IPE 550 |

*requires use of 80 mm deep decking and 150 mm deep slab

(a) Sizes of secondary beams

| Span of Primary Beam (B) | Span of Secondary Beam (A) | | | |
|--------------------------|----------------------------|---------|---------|---------|
| | 6 m | 8 m | 10 m | 12 m |
| 5 m | IPE 270 | IPE 300 | IPE 330 | IPE 400 |
| 6 m | IPE 270 | IPE 300 | IPE 360 | IPE 450 |
| 7 m | IPE 300 | IPE 330 | IPE 400 | IPE 500 |
| 8 m* | IPE 300 | IPE 360 | IPE 450 | IPE 550 |

(b) Sizes of primary beams

Table 5.2 Design tables for composite beams

| | |
|----------------------------|--|
| Fire Resistance | Composite slabs achieve a fire resistance of up to 120 minutes using only mesh reinforcement, provided they are designed as continuous over one or more internal spans. Additional reinforcing bars can be placed in the deck ribs in heavily loaded areas (e.g. plant rooms). Fire protection to the beams can be provided by the same measures as for precast concrete slabs. |
| Acoustic Insulation | Composite slabs achieve excellent acoustic insulation provided a suitable resilient floor covering is used. The key aspect is the interface between separating walls and the steel beams in which case, the space between the deck ribs must be filled by mineral wool to avoid acoustic losses over the wall and through the slabs. |
| Load span Tables | Composite beams supporting composite slabs are relatively shallow and may be designed for a span:depth ratio of approximately 24. Composite beams are very stiff for control of floor vibrations. The critical design case is control of total deflections, which are limited to a maximum of span/200. The steel beam deflection is caused by the weight of wet concrete supported during construction. The load-span tables in Table 5.2 may be used for composite beams with a 130 mm deep composite slab and 60 mm deep decking (except where shown by *). |

Integrated Beams or Slim Floor Construction

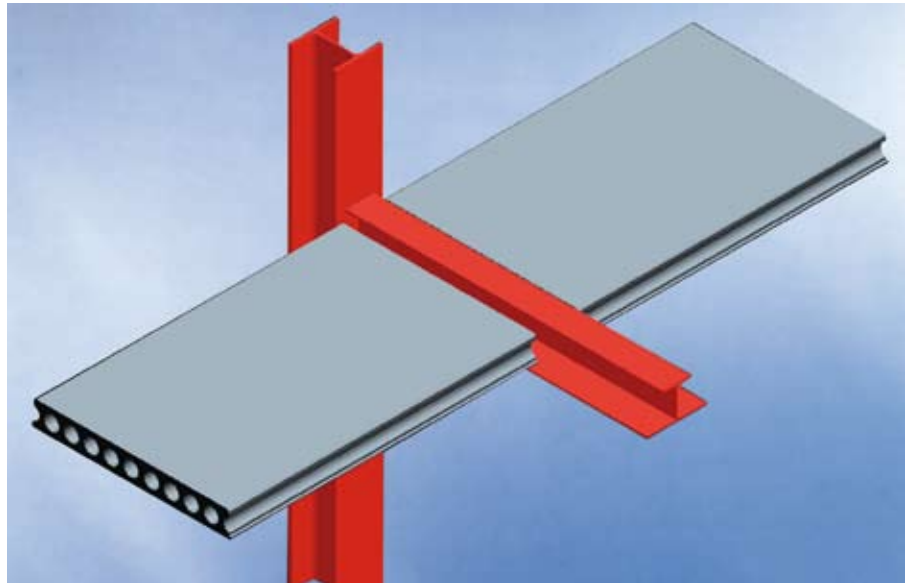

Figure 5.4 Integrated floor beams supporting precast concrete slabs

Description

Integrated beams (also known as slim floor beams) support a precast concrete slab or deep composite slab so that the beam and slab occupy the same depth. These sections can be of various forms:

- HE or UC sections with a welded bottom plate.
- IPE sections cut at mid-height and welded to a bottom flange plate.
- Rolled ASB beams of asymmetric cross section.
- RHS with a welded bottom plate, often used for edge beams.

Where integrated beams support hollowcore concrete slabs, as shown in Figure 5.4, the slabs often span a longer distance than the beams, so that the depth of the slab and beam are compatible. A concrete topping is generally used. Integrated beams are designed to achieve minimum structural depth.

Main Design Considerations

Integrated beams supporting hollowcore slabs are designed so that the slab spans up to 9 m and the beam spans 6 to 7.5 m. The critical design case is that of torsion acting on the beam during construction and loading due to unequal adjacent spans. Integrated beams using deep composite slabs can span up to 9 m when spaced at 6 m.

Advantages

- Fast construction process.
- No limit on building height, subject to design and location of suitable bracing arrangements.
- Long span beams provide open plan space and freedom in internal partitioning.
- Integrated beams or slim floor beams minimize the floor depth.

Fire Resistance

For integrated beams or slim floor beams, the partial encasement of the steel section in concrete achieves up to 60 minutes fire resistance. Additional fire protection can be applied to the bottom flange by various methods, such as:

- Board protection, for example by plasterboard.
- Intumescent coatings applied on site or in the factory.

Boards are most practical for columns. Intumescent coatings maintain the profile of the member and are thin (1 to 2 mm thick). These coatings can be applied off-site.

Acoustic Insulation

Integrated beams with hollowcore slabs and a concrete topping or slim floor beams with deep composite slabs achieve excellent acoustic insulation. Special detailing measures can be required for both acoustic insulation and fire resistance.

Loads and Deflections

The size of integrated beams with a 12 mm welded bottom flange plate and supporting hollowcore concrete slabs are presented in Table 5.3. The sizes of ASB beams supporting deep composite slabs are presented in Table 5.4. The overall floor depth including acoustic layers is 350 to 450 mm.

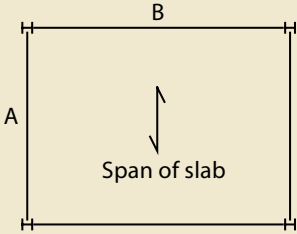
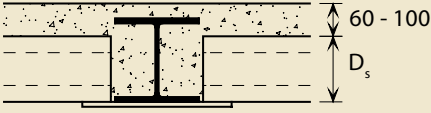
| A (m) | D _s |
|-------|----------------|
| ≤6 | 150 |
| ≤7 | 200 |
| ≤8 | 250 |
| ≤10 | 320 |

(a) Plan view of floor (b) Cross-section through integrated beam (c) Minimum depth of precast concrete units

| Span of Slab (A) | Span of Integrated Beam (B) | | |
|------------------|-----------------------------|---------|---------|
| | 6 m | 8 m | 10 m |
| 6 m | HE 220A | HE 280A | HE 300B |
| 7 m | HE 240A | HE 280B | HE 320B |
| 8 m | HE 240B | HE 300B | HE 340B |

Slab depth chosen so that propping is not required

Table 5.3 Design tables for integrated beams supporting precast concrete slabs

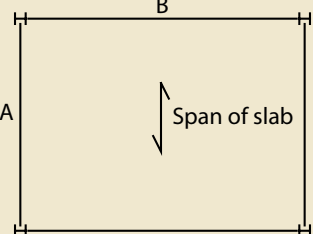
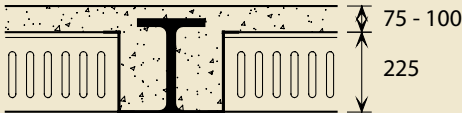
(a) Plan view of floor (b) Cross-section through ASB beam

| Span of Slab (A) | Span of ASB Beam (B) | | |
|------------------|----------------------|-------------|-------------|
| | 6 m | 8 m | 10 m |
| 6 m | 280 ASB 100 | 280 ASB 136 | 300 ASB 196 |
| 7 m | 280 ASB 100 | 300 ASB 153 | 300 ASB 249 |
| 8 m | 280 ASB 136 | 300 ASB 153 | 300 ASB 249 |

Table 5.4 Design tables for ASB beams in Slimdek supporting deep composite slabs

Inverted Steel Beams



Figure 5.5 Inverted steel beams (*Slimline*)

| | |
|-----------------------------------|--|
| Description | <p>Inverted steel beams are used in the <i>Slimline</i> system and comprise IPE sections cast into a concrete slab that acts as the underside of the floor, as shown in Figure 5.5. The space between the beams, which are located at 600 mm centres, can be used to support services above the slab. The upper floor surface uses floor boarding or a thin composite slab.</p> |
| Main Design Considerations | <p>The <i>Slimline</i> system is manufactured in the form of prefabricated slabs and inverted beams of up to 2.4 m width, which are supported directly on primary beams. Therefore the combined depth of the secondary and primary beams is crucial to the use of the system, and primary beams should be carefully located to align with the separating walls.</p> <p>This system can span up to 12 m, depending on the beam size that is chosen. The inverted slab is typically 70 to 100 mm thick and services and lighting can be incorporated, as part of the slab.</p> |
| Advantages | <ul style="list-style-type: none"> • Prefabricated long span floor system. • Essentially a dry construction process. • Concrete slab forms the ceiling. • Services can be located between the beams. |
| Fire Resistance | <p>The <i>Slimline</i> system provides excellent fire resistance due to the inverted concrete slab, and a slab depth of 100 mm would normally, achieve 90 minutes fire resistance. The beams can be fire protected, but in many cases, the reduction in direct fire exposure can be used to justify the use of unprotected beams. Primary beams should be protected conventionally.</p> |
| Acoustic Insulation | <p>This system achieves excellent acoustic insulation provided the joints in the precast slabs are sealed.</p> |
| Loads and Deflections | <p>The maximum span:depth ratio of the partially encased beams is approximately 18. The optimum span of the floor plate is 8 to 10 m for an overall floor depth of 500 to 600 mm, not including the primary beams.</p> |

06 Modular Systems

This section describes the various forms of modular construction using 3 dimensional units. They can be designed independently, or as part of 'hybrid' steel construction systems, which are described in the following sections.

Modular construction uses load-bearing 3 dimensional units, which create self supporting structures up to 8 storeys high. The modules are manufactured in factory controlled conditions, and are repetitive units made in lengths and widths suitable for transportation and installation.

Modular construction has been used most effectively in hotels, student residences and social housing, as shown in Figure 6.1, where economy of scale in manufacture can be achieved.

There are three generic forms of modular construction:

- Fully modular construction using load-bearing modules.
- Modules supported by a separate steel structure or bracing system.
- Non-load-bearing 'pods' for bathrooms etc.

The structural use of these modules is presented, but 'pods' are not described, as they tend to be smaller and are non-structural.

Fully Modular Construction

Steel Frames and Modular Construction



*Figure 6.1 Modular residential building with integral balconies, London
AHMA Architects & Yorkon*

Fully Modular Construction



Figure 6.2 Module with load-bearing walls
Terrapin

Description

There are three generic forms of modular construction:

- Modules in which vertical forces are transferred through the side walls to the module below – see Figure 6.2.
- Modules with fully or partially open sides in which vertical forces are supported by edge beams and corner posts - see Figure 6.3.
- Non load-bearing modules supported on floors or a separate structure.

Many 'hybrid' forms of modular construction exist when modules are combined with other structural elements, such as:

- Modules supported on a steel or concrete podium which permits the open space beneath to be used for commercial use or car parking.
- Modules combined with 2 dimensional floor and wall panels.

Modules use light steel walls and floors with Square Hollow Sections or angles for the corner posts, which are similar to those described for walls and floors in Section 3.

Main Design Considerations

The main design considerations in the choice of modular construction are:

- Ability to use repetitive cellular units.
- Transportation and installation requirements.
- Ability to create open plan space where required.
- Building height and requirement for open space, particularly at the ground floor.

Modules are manufactured in widths of 2.7 to 4.2 m, which is the maximum for transportation on most major road networks. Internal dimensions of up to 3.6 m are more practical in residential applications (3.8 m external dimensions). Module lengths up to 12 m can be used, although 7.5 to 9 m is more practical.

The plan form of a typical modular building in which adjacent modules are combined to create larger rooms, is shown in Figure 6.3.



Figure 6.2 Module with edge beams and corner posts
Kingspan

Advantages

- Speed of construction (up to 60% faster than site-intensive construction).
- Improved quality due to off-site manufacture.
- Excellent acoustic insulation due to use of double skin walls and floors.
- Economy of scale in manufacture of repetitive modular units.
- Partially open-sided modules are more useful for apartments.

Fire Resistance

A fire resistance of 60 minutes is provided by using two layers of fire resisting boards to the walls and ceiling. It is also necessary to provide 'fire stops' between the modules to prevent passage of smoke and fire.

Acoustic Insulation

A high level of acoustic insulation (over 60 dB sound reduction) is achieved due to the double layer construction of the walls and combined floor and ceiling.

Loads and Deflections

Modular design is influenced by:

- Load-bearing resistance of the wall studs.
- Stability under wind action.
- Robustness to accidental actions.

For 4-sided modules, stability can be achieved by suitable bracing in the walls or by diaphragm action of the boards attached to the walls. For corner-supported modules, as shown in Figure 6.2, the design is influenced by the compression resistance of the corner posts and the spanning capabilities of the edge beams. Corner-supported or open-sided modules generally have to be stabilised by a separate structure. The modules are tied together at their corners so that they act together structurally.

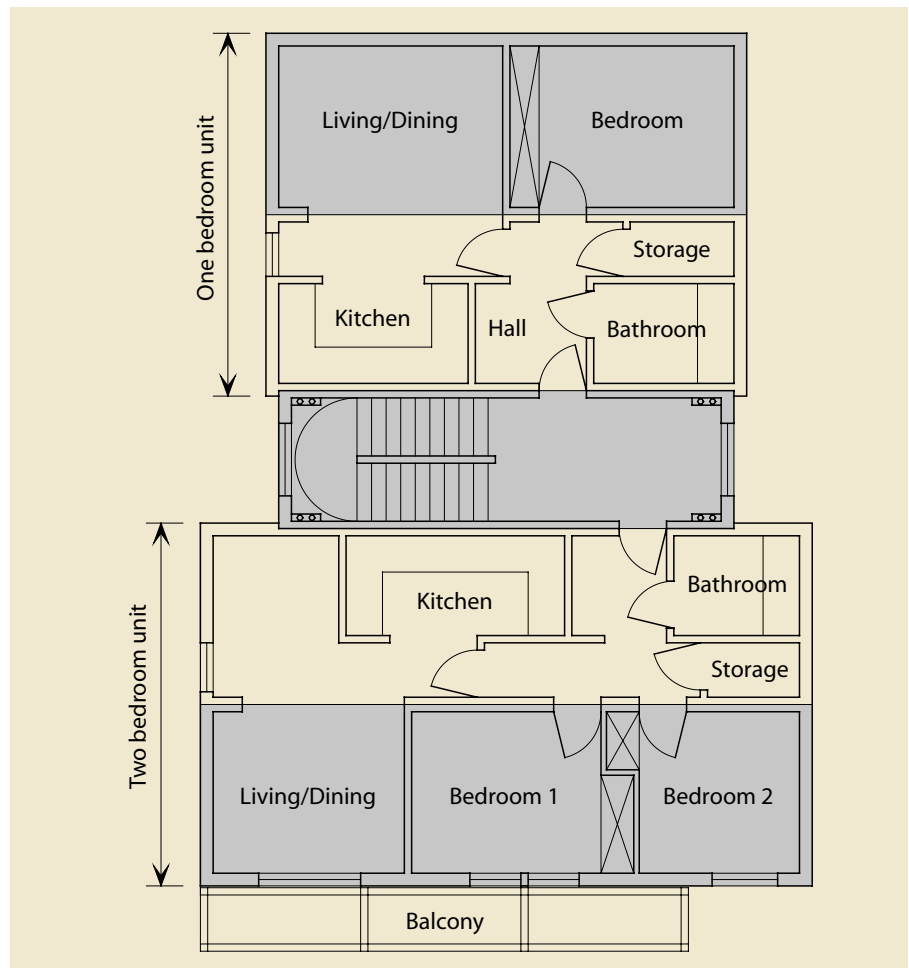

Figure 6.3 Plan form of modular residential building – alternate modules shown shaded

Overall Floor and Wall Zone

The overall floor zone is dependent on the combined depth of the floor and ceiling and may be taken for planning purposes as:

- 400 mm for smaller modules (< 3.6 m wide);
- 500 mm for larger modules (< 4.2 m wide);
- 600 mm for open sided modules with edge beams.

The combined width of the adjacent walls of modules may be taken as:

- 250 mm for low-rise modules;
- 300 mm for multi-storey modules with corner posts.

The space between the modules allows for installation tolerances. Balconies can be created within the module, as shown in Figure 6.1, or by attaching projecting balconies to the corner posts of the modules. Stair modules may also be introduced as part of the modular concept, which may influence the overall floor zone. In this case, it is recommended to use a 500 mm floor and ceiling zone for planning purposes.

Steel Frames and Modular Construction



Figure 6.6 Modular building supported on a podium level and stabilised by a braced steel structure around the stairs

Description

Many types of buildings require more open plan space and in this case, modular units can be combined with a primary steel frame. Three generic forms of combined use of steel frames and modules exist:

- Modules supported on a steel podium, in which the locations of the columns in the podium are aligned with multiples of the module dimensions above.
- Modules with fully or partially open sides supported by a steel framework at every floor level.
- Modules that are stabilised by a braced steel or concrete core.

Where the modules are stabilised by a core or supported on a podium level, their design is similar to that described earlier. Where supported by a separate steel framework, the modules can be designed as non load-bearing. An example of a podium structure and a braced stair core is shown in Figures 6.6 and 6.7.

Main Design Considerations

Where supported by a separate steel framework, the modules are of similar size to the load-bearing modules described earlier. The beams of the supporting structure are located below the load-bearing walls of the modules. For efficient car parking at ground or below ground, two 3.6 m wide modules with a supporting beam span of 7.2 m are efficient for use of 3 car parking spaces below. Cellular beams or fabricated sections are effective in providing open plan space below podium level.

The combined use of modular units and planar floors is advantageous when modular units are used for the highly serviced areas, such as bathrooms and kitchens, as illustrated in Figure 6.8.

Advantages

- No limitation on building height.
- Podium level creates open plan space and car parking below.
- Suitable for mixed residential and commercial use.

Fire Resistance

The steel frame should be fire protected conventionally. The preferred protection system is likely to be intumescent coatings in order not to increase the dimensions of the steel sections. Use of Square Hollow Section columns is advantageous.



Figure 6.7 Completed modular building in Figure 6.6

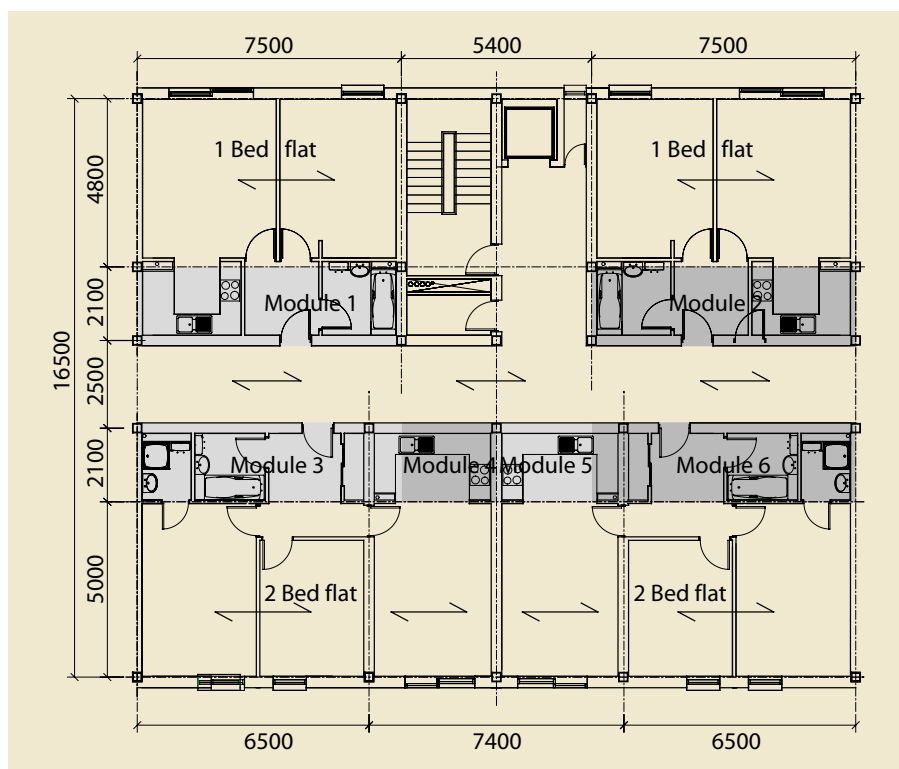

Figure 6.8 Combined use of modules with a steel framework

Acoustic Insulation

Acoustic insulation is independent of the use of the steel support structure when using modular construction.

Loads and Deflections

The steel beams should be designed for combined bending and torsion when loaded unequally by adjacent modules. Asymmetric steel sections may be advantageous.

07 Façade & Roof Systems

This section reviews the various forms of cladding that can be used in combination with light steel walls. The characteristics of the cladding systems are presented, particularly in relation to thermal performance. Roof systems based on steel components are also reviewed.

Façade systems are supported by light steel external walls, which themselves are load-bearing or alternatively, are infill walls within a primary steel or concrete frames. The same principles and details apply to both systems. Three generic forms of cladding are considered:

- Brickwork, which is usually ground supported and laterally restrained by the walls.
- Metallic or board-type cladding.
- Insulated render bonded through insulation to a rigid backing board.

The principle design requirements are those of weather-tightness, thermal insulation and air-tightness. The details of these cladding systems are presented.

Roofs can also be designed in steel in the form of roof trusses, purlins, composite panels and roofing sheeting with insulation. Open roof systems can be created, which provide habitable space efficiently.

Façade Systems

Roof Systems

Figure 7.1 Residential building in light steel framing and with metallic cladding in Glasgow
Peck and Reid Architects & Metsec



Façade Systems



Figure 7.2 Insulated render combined with clay tiles attached to light steel infill walls

Description

There are two generic cladding types suitable for use within the external wall systems described earlier:

- Ground supported or floor supported cladding, such as brickwork.
- Lightweight cladding that is supported by the light steel wall.

In multi-storey buildings, brickwork requires support by stainless steel angles attached to the perimeter beams. Lightweight cladding is of various forms, such as:

- Insulated render.
- Clay tiles or brick slips attached to horizontal ribs.
- Metallic cladding, such as composite panels.
- Boards of various types.

Where glass panels are used, they are often integrated into the wall itself or attached directly to the floor on a separate sub-frame.

Prefabricated light steel wall panels can be designed with pre-attached cladding, and in this case the joints are crucial to the design concept. Examples of prefabricated wall panels using light steel framing are shown in Figures 4.1 and 4.5.

Main Design Considerations

The main design considerations in the choice of the façade system are the:

- Means of vertical and lateral support to the cladding.
- Provision of the required level of thermal insulation with minimal 'cold bridging'.
- Provision of openings (windows and doors) and attachments.
- Opportunities for prefabrication of the façade panels, with attached cladding.

When using light steel framing to support the façade, insulation is normally placed externally to the light steel elements and is supplemented by additional mineral wool between the wall studs.

Brickwork is attached by wall ties to vertical 'runners' that are screw fixed through the external insulation to the wall studs at nominally 600 mm centres, as shown in Figure 7.3. The wall ties are fixed every fifth course (or at 375 mm vertically) leading to 2.5 ties per m² area. Additional ties are required around openings. Brickwork is self supporting up to 12 m high (4 storeys) but taller buildings require additional vertical support at every or alternate floors. This is only practical with a steel framework and not with light steel framing.

Examples of cladding details using metallic cladding and insulated render are shown in Figures 7.4 and 7.5. In both cases, use of a sheathing board is recommended.

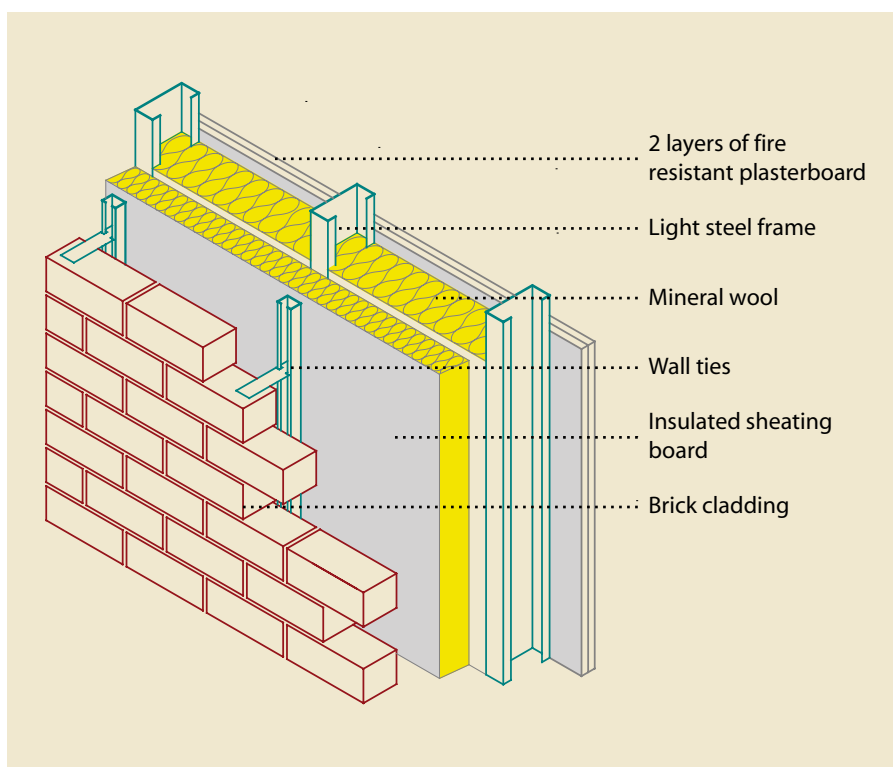

Figure 7.3 External wall with brick cladding attached to light steel framing

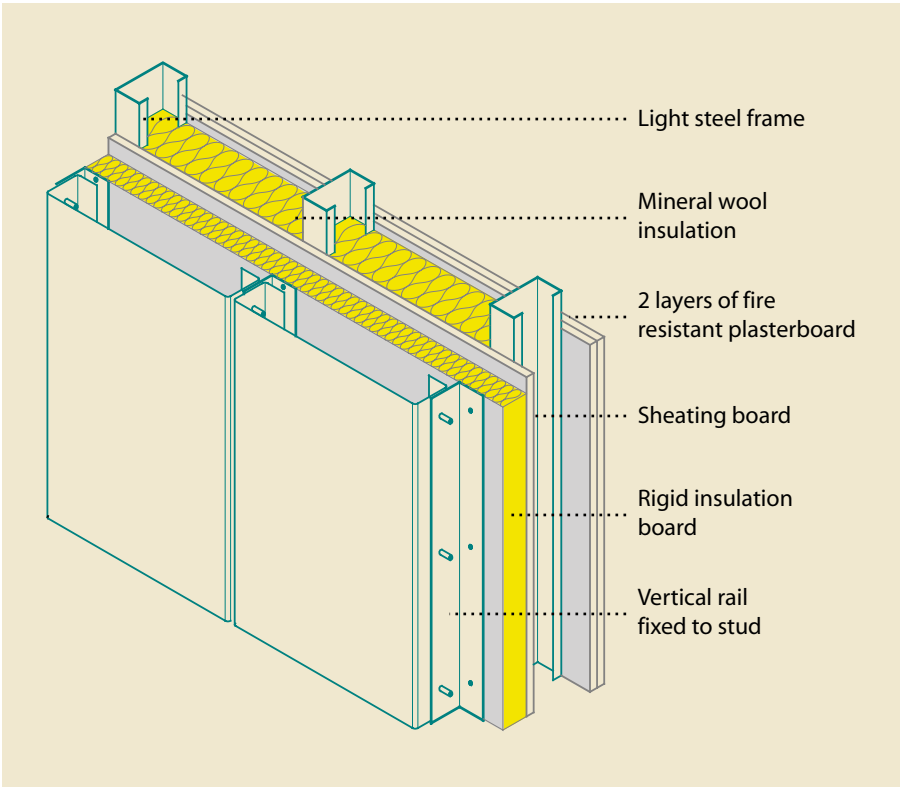

Figure 7.4 External wall with metallic cladding attached to light steel framing

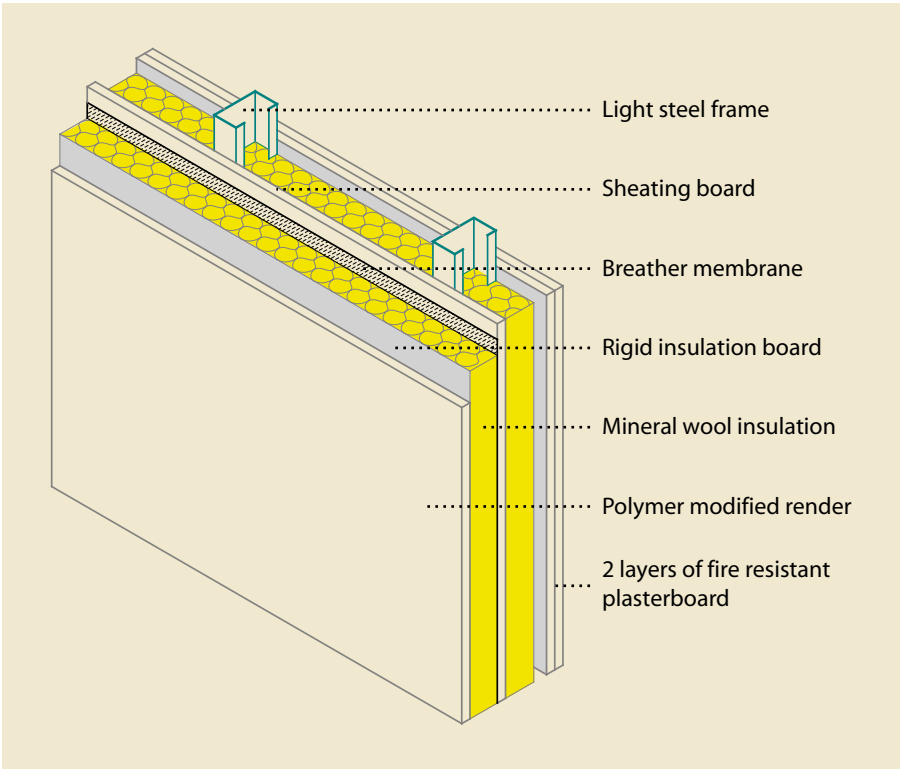

Figure 7.5 Insulated render attached to light steel framing

| | |
|---------------------------------|--|
| Advantages | <ul style="list-style-type: none"> • A wide variety of cladding materials may be used. • Lightweight cladding can be supported by the light steel walls. • Large panels can be prefabricated with their cladding attached. • High levels of thermal insulation (low U-values) can be achieved. • Walls are thinner than in blockwork or concrete construction. |
| Thermal Performance | <p>U-values below 0.25 W/m²K can be achieved for walls with brick cladding and below 0.2 W/m²K for walls with insulated render. Slotted or perforated studs (Figure 7.6) reduce cold bridging and allow more insulation to be placed between the studs without causing condensation. For this reason, 150 mm deep slotted studs with 30 mm of external insulation board and 150 mm of mineral wool insulation between the studs can be thermally very efficient.</p> |
| Acoustic Insulation | <p>Acoustic insulation is rarely specified for cladding systems but most lightweight cladding providing a U-value less than 0.25 W/m²K achieves an airborne sound reduction of over 30 dB. Brick cladding achieves a higher airborne sound reduction of over 35 dB.</p> |
| Overall Wall Thicknesses | <p>The overall wall thickness depends on the type of cladding used and the following dimensions may be used for cladding systems achieving a U-value of 0.25 W/m²K:</p> <ul style="list-style-type: none"> • Brickwork: 350 mm. • Insulated render: 250 mm. • Metallic or board cladding: 250 mm. |

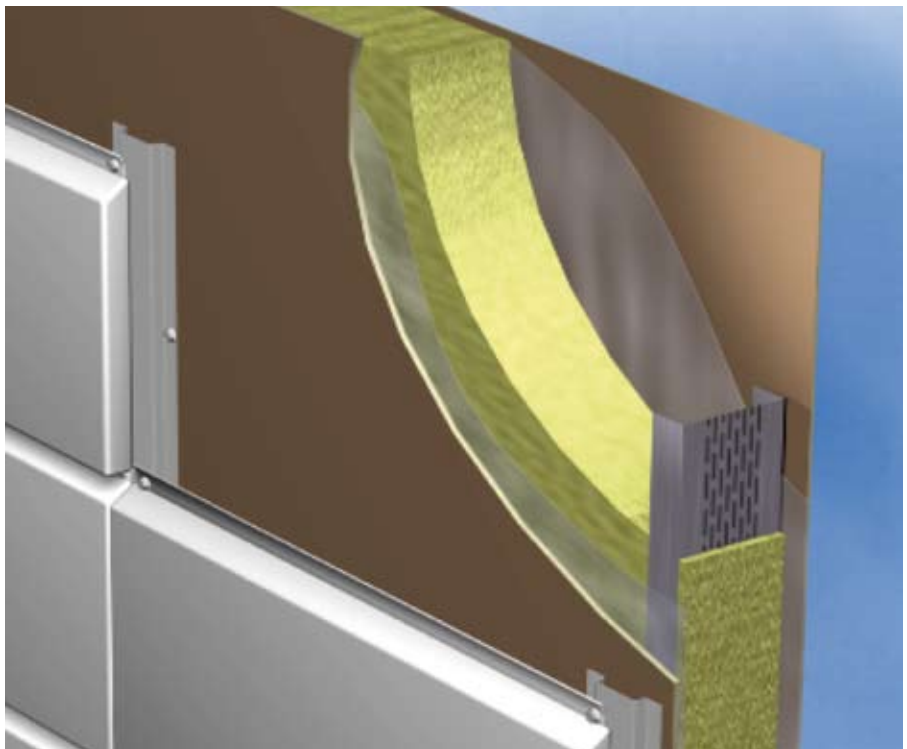

Figure 7.6 Slotted studs used with mineral wool and metallic cladding
Ruukki

Roof Systems

Description

Various roof options can be considered when using steel construction. These are:

- Steel purlins spanning between structural frames or cross walls.
- 'Open roof' system designed to create habitable space.
- Prefabricated steel roof cassettes.
- Composite panels (for spans up to 6 m).

Steel roofs can be manufactured to a wide range of shapes including curved and hipped forms. Metallic cladding is suitable for shallow roofs and curved shapes.

Main Design Considerations

The two main considerations are; the span direction of the roof and the level of thermal insulation. Roofs can span either:

- From façade to façade, with spans of 8 to 12 m, or;
- Between cross-walls with spans of 5 to 8 m.

In the first case, a traditional roof truss is preferred, but in the second case, purlins or other systems permit for use of the roof space. An 'open' steel roof system, which provides habitable space, is shown in Figure 7.7.

For roofs, the required level of thermal insulation is usually high (U-values < 0.15 W/m²K) and so the total thickness of thermal insulation can be as much as 150 mm. The majority of the insulation is placed externally to the steel roof, i.e. trusses or purlins, but up to 30% of the insulation can be placed between the steel members without risk of condensation.

Composite panels can be manufactured with a tiled appearance, as shown in Figure 7.8. Photovoltaic panels or thermal collectors can be easily attached to steel cladding and its sub-structure.

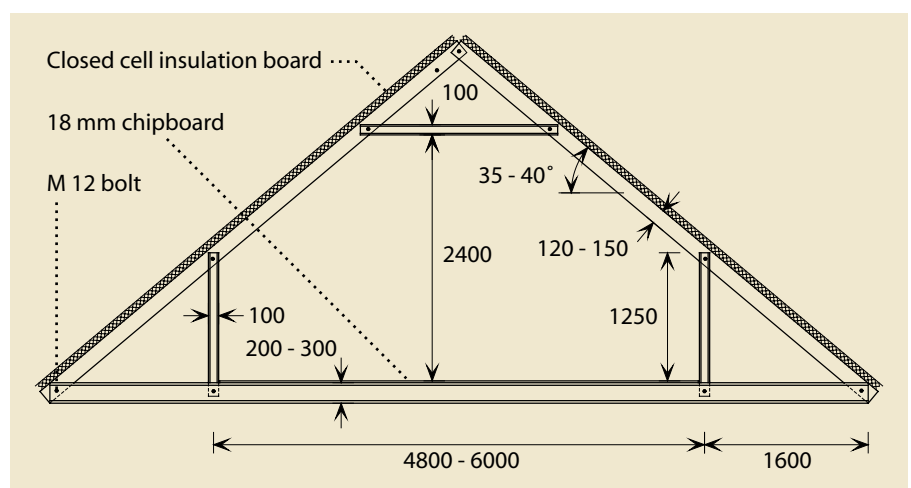

Figure 7.7 'Open' roof system using light steel C sections



*Figure 7.8 Tiled composite panel system being installed
Kingspan*

08 National Practice

In this section, national practices in housing and residential buildings are presented for several countries. These construction practices may follow or adapt the systems described in this Guide. Some new systems are presented which may be used more widely in Europe.

Current Practice in the UK

In the UK, approximately 180,000 houses and apartments are built annually. The market for all steel technologies in the residential sector is good, particularly in the medium rise buildings and in single person accommodation. Overall, the market share for steel is about 7% in housing and residential buildings. All the forms of construction presented in this Best Practice guide are used, but the noticeable trends are in the use of:

- Light steel framing for 4 to 6 storey apartments.
- *Slimdek* and light steel infill walls for 6 to 15 storey residential buildings, requiring more flexible use of space.

- Modular construction for single person units, such as student residences, for buildings up to 10 storeys high.
- Mixed use of modular construction with a concrete core for stability in high rise applications, or with a supporting steel structure at podium level for 6-8 storey buildings.

The challenges for this sector are to build to higher density and more rapidly in urban locations, and to satisfy the Code for Sustainable Homes, which is now embodied in UK Regulations. More efficient construction systems are preferred from the point of view of speed of installation and thermal performance, which steel technologies can provide.

UK

The Netherlands

France

Sweden



Figure 8.1 Housing project using light steel framing (Basingstoke)
HTA Architects



Figure 8.2 Modular residential project in Basingstoke, UK
PRP Architects & Vision

The following practices in the UK are described in more detail:

Light Steel Framing

Light steel framing uses the technologies presented earlier, but there are noticeable trends which should be recognised in the use of:

- single leaf load-bearing walls;
- mixed use of light steel floors and steel beams for longer spans;
- mixed use of composite slabs and light steel walls;
- mixed use of steel beams and light steel floors.

The market for infill walls in both steel and concrete framed buildings has also grown considerably.

Slimdek

Slimdek has achieved a wide market in the residential sector because of the need to provide flexibility in layout of rooms and to achieve the maximum

useable area and minimum depth of floor without downstand beams. Light steel infill walls are also incorporated.

Slimdek has been used in buildings up to 16 storeys (see Figure 2.2).

Modular Construction Stabilised by Concrete Core

Modules can be designed efficiently if the building is stabilised by steel bracing or by a concrete core, for example, as the 17 storey residential building, Paragon – see Case Studies. Other projects have also used modules and concrete floor slabs, as shown in Figure 8.2, in order to satisfy fire resistance and acoustic insulation requirements for taller buildings.

Modular Construction Supported by a Separate Structure

As described in Section 6, modular construction can be combined with a steel podium or platform level to create open plan space below for commercial or communal uses or car parking.

Modules can also be designed with an ‘Exo-skeleton’ as in the MOHO project in Manchester, shown in Figures 8.3 and 8.4. This technique is widely used to extend the range of application of modular systems and to create self-supporting balconies.

Current Practice in the Netherlands

Introduction

Over 70,000 houses are built every year in the Netherlands, and approximately 100,000 tonnes of steel are consumed per year in this sector. Additionally tens of thousands of tonnes of steel are used in the renovation sector, in which steel is a very popular building material.

The application of steel in the residential sector is very diverse. In housing developments with a ‘modern look’, profiled colour-coated steel sheeting is used for cladding and roofing. In the majority of Dutch houses, steel is used in

Figure 8.3 *Steel external framework combined with highly glazed modules, MOHO, Manchester Yorkon and Shed KM Architects*



Figure 8.4 *Completed MOHO building Yorkon and Shed KM Architects*



small elements, such as lintels above window openings and supporting beams above garage doors. However, steel frames are widely used in apartment buildings.

As in other European countries, lightweight prefabricated steel systems have advantages in urban projects. Many of the forms of construction presented in this Best Practice guide are used, but the noticeable trends in the Netherlands are:

- Light steel framing for roof top extensions to create apartments and maisonettes in renovated flat-roofed apartment buildings.
- Light steel framing for the transformation of non-residential buildings (offices, industrial buildings) into apartments.
- Steel frames using hot rolled sections with a variety of floors (precast concrete, composite and light steel joists) in apartment buildings.
- Variety of steel components in detached, semi-detached and terraced housing.

Roof top Extensions

Roof-top extensions have become a niche market for steel in the Netherlands. Many existing buildings with a concrete construction and a flat roof can be extended by adding one, two or even more floors and light steel framing is well suited for this purpose. There are many interesting projects, for instance: Leeuw van Vlaanderen in Amsterdam (Winner of the National Renovation Prize 2007) and recently Het Lage Land in Rotterdam (Figure 8.5) and De Bakens in Zwijndrecht.

The light steel frame elements are self-supporting, resulting in a very lightweight building method. Building physics and fire resistance requirements are easy to meet with layers of gypsum board. Heat loss through outer walls is minimised by insulation materials, such as mineral wool. Floor vibrations can be reduced by adding a gypsum screed.

Many disused buildings are in desirable locations such as harbours and city centres, and are being transformed into high quality

apartments and commercial space.

The renovation and roof top extension of the warehouses Nautilus and IJsviss in The Hague (Figure 8.6) is a good example. The additional penthouses in steel-and-glass architectural style offer a spectacular harbour view. The building method is a mix of structural steel and light steel framing.

Apartment buildings

In parallel with the increasing use of steel structures in commercial buildings, several multi-storey apartment buildings with steel frames have recently been completed.

A wide variety of floor systems are in common use: precast hollow core slabs (such as Het Baken in Deventer), solid concrete planks (Montevideo in Rotterdam), composite slabs (Schutterstoren in Amsterdam), inverted steel-concrete (La Fenêtre in The Hague - see Case Studies) and light steel framing (Linea Nova in Rotterdam).



Figure 8.5 Roof-top extension with maisonettes: Het Lage Land in Rotterdam

Figure 8.6 Transformation of an old warehouse with a spectacular view: Nautilus & IJsviss in The Hague (Winner National Steel Prize 2006, category Residential buildings).



Town houses

For nearly a century, private ownership of housing has been subsidised by the Dutch government. The desire for expressive architecture and large window openings has led to the use of structural steelwork and façade elements in detached, semi-detached and terraced housing. An example in a transparent architectural style using steel construction is shown in Figure 8.8.

The *Smart House* concept was developed by Architect Robert Winkel and uses Square and Rectangular Hollow Section beams and light steel floor cassettes and infill walls. It is based on a 5.4 m column grid. Although few buildings using this concept have been built, it is a very practical system for larger residential buildings and smaller office buildings (Figure 8.9).

Current Practice in France

The housing market in France is approximately 300,000 per year, of which approximately 50% comprises apartments. The social housing sector has always been active in France, and many social housing associations design and procure their own buildings.

Steel construction has reached a market share of 7%, mainly through the *Maison Phénix* system of house building. More recently, composite construction has achieved a breakthrough in the multi-storey residential sector. Modern building projects in France increasingly adopt the sustainability criteria according to the HQE system (*Haute Qualité Environnementale*).

PRISM

The PRISM (*Produits Industriels et Structures Manufacturées*) is a concept based on a steel structure suitable for residential buildings.

A variety of slab systems can be used with the PRISM concept, including plain reinforced concrete slabs, prefabricated reinforced hollow core concrete slabs and composite slabs.

PRISM generally uses external walls, which are light steel infill walls supported by the floor slabs. Thermal insulation is fixed externally to the wall and the light steel sub-frame forms the internal skin of the façade system. The sub-frame spans from slab to slab and thermal and acoustic insulation was provided by mineral wool and plasterboard (see Figure 8.10).



Figure 8.7 Multi-storey apartment building with a steel structure: Schutterstoren in Amsterdam.



Figure 8.8 Town houses: House De Kom in Oranjewoud.



Figure 8.9 (Above & right) Smart House, Rotterdam using Square & Rectangular Hollow Sections with light steel infill walls & floor joists

Two façades systems are used – one is for heavy weight elements such as terracotta, and the other is for lightweight elements such as insulated render. Both cladding systems use an adapted steel sub-frame, which provides for a wide range of design solutions.

Internally to the cladding elements, the wall is made up as follows:

- Two 13 mm thick fire resistant plasterboards providing 60 minutes fire resistance.
- A void of 60 to 100 mm permitting the inclusion of insulation to the slab edge and the steel columns.
- 70 to 100 mm thick mineral wool insulation.
- Light steel sub-structure wall which comprises horizontal rails and vertical studs.

The total thickness of the internal elements is about 160 mm. The slab edge and columns are thermally protected from outside by insulation, thereby avoiding thermal bridging. The total thickness of the wall can vary between 290 and 360 mm.

Separating walls and partitions are made of plasterboard fixed on an internal steel sub-frame and using mineral wool for acoustic insulation. This technique is widely used for building construction. It permits re-configuration of the floor layout after several years of use.

Cofradal slab system

Cofradal is a lightweight floor slab that uses a thin steel 'tray' into which rigid mineral wool is fitted and a thin concrete screed is placed on top. It is 200 mm deep overall, as illustrated in Figure 8.13, and may be used for both commercial and residential buildings. Composite action is achieved between the tray and concrete.

PCIS slab system

PCIS is a dry system for slabs used in residential buildings. Asymmetric beams are integrated into the slab depth. The sections can be fabricated or a steel plate may be welded under the lower flange of a HE section. The beams span up to 6 m and are simply connected to the columns. The overall slab depth is 320 mm.

The construction system is as follows (from bottom to top):

- The slab comprises galvanised profiled steel sheeting (1.5 mm thick) that is screwed to the supporting beams.
- Fibreglass layer, 3 mm thick (230 g/m²), provides support for a triplex wooden panel, 12 mm thick. These panels are screwed onto the steel sheeting.
- 12 mm thick plasterboard with a hard finish provides the upper wearing surface.

Suitable ceiling materials are:

- Thermal and acoustic insulation: 45 mm thick mineral wool (30 minutes fire resistance) or 70 mm thick rock wool (60 minutes fire resistance).
- Two 12 mm thick plasterboard (30 minutes fire resistance) or two 12 mm fire resisting boards (60 minutes fire resistance).

Maison PHÉNIX

Maison Phénix is the leader in the French market with about 6,000 houses delivered per year and with 50 years of



Figure 8.10 The PRISM system during construction: Steel frame, roof and external light steel walls ready to receive external skin



Figure 8.11 PRISM system: Example of external envelope with stone cladding
Architect: P Sartoux



Figure 8.12 Example of building constructed using the PRISM system

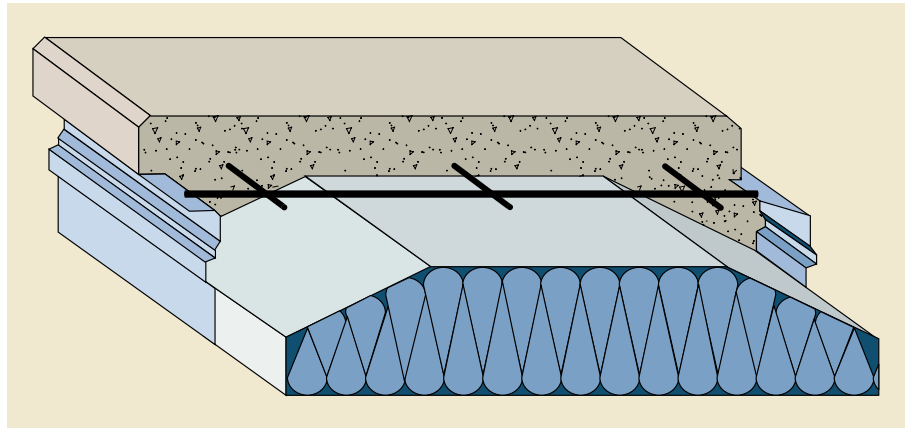

Figure 8.13 Cofradal lightweight slab units – typical cross section and panels during installation

experience. The steel frame is made from IPN / IPE or angle sections. The adaptability and the customisation of products create a wide range of housing forms with a variety of façades.

Details of this housing system used mainly for single storey houses is shown in Figure 8.14.

Current Practice in Sweden

Introduction

In Sweden, the main application of steel is in slim floor construction (offices and housing) and in light steel walls, often using slotted or perforated C sections. It is possible to create very shallow floor structures, which is important in Sweden.

Labour costs are a large part of the total cost of the finished construction and reduced construction time on site is also very important.

Slim Floor Systems

Slim floor systems have shallow beams, whose long spans achieve flexibility of apartment layout. The low height depends not only on the floor itself, but also on the edge beams and internal beams that are designed with wide bottom flanges. The junction between the supporting beam and the hollow core slab are filled with concrete. The steel beams are then protected by the surrounding concrete. In residential buildings, it is common to build a secondary floor system.

Horizontal services can then be installed between the upper and the lower floor elements.

Light Steel Construction

A light steel floor consists of load-bearing cold formed steel profiles and slabs, as described in Section 3. It can be built on site, or prefabricated in the form of cassettes or elements which are then installed on site. A common floor construction consists of C profiles at a spacing of 600 mm. The section height of the joists is between 150 and 300 mm, depending on the span. Trapezoidal decking is fixed to the upper flange and can also transfer load in the horizontal plane. The maximum floor span is about



Figure 8.14 *Maison Phénix during construction, showing the roof details for a single storey house*



Figure 8.15 Example of 7 storey residential building using slim floor construction in Sweden

8 m when using 300 mm deep C sections. The current experience is that light floor structures with a span of 4 to 4.5 m are most economical in housing and effective detailing ensures good acoustic insulation.

Light steel constructions are used as load-bearing systems in residential buildings of up to three storeys. It is common that light steel buildings are combined with

other stabilising systems such as rolled or welded steel sections. The total floor weight is less than 150 kg/m² floor area.

Modular Construction

The *OpenHouse* modular system has been used in Annestad in Malmö and is based on a 3.9 m column grid. The application of *OpenHouse* is presented in the Case Studies.

09 Case Studies

A series of Case Studies is presented in this section to illustrate the design and construction principles discussed earlier. The Case Studies cover a range of building forms and locations throughout Europe.

The Case Studies and their structural systems are summarised as follows:

- *Paragon*, London. A series of residential buildings comprising 4 to 17 storeys of modules clustered around concrete cores.
- *Social Housing*, Evreux. 4 storey residential building using a dry construction system.
- *La Fenêtre*, The Hague. Multi-storey residential building supported on inclined steel columns.
- *Bioclimatic Towers*, Vitoria-Gazteiz. Four highly sustainable 16 storey towers constructed in steel.
- *OpenHouse*, Malmö. Modular housing system for 4 storey apartments.

Paragon, London

*Social Housing,
Evreux, France*

*La Fenêtre,
The Hague, NL*

*Bioclimatic Towers,
Vitoria-Gazteiz, Spain*

*OpenHouse,
Malmö, Sweden*

Paragon, London

Britain's tallest modular building has been completed for developer Berkeley First, and provides affordable accommodation in West London. This project uses 17 storeys of modules clustered around a concrete core.

Application Benefits:

- Modular construction up to 17 storeys
- Rapid construction system
- Minimises logistical problems on site
- Excellent acoustic insulation
- Open sided modules provide for flexible space planning
- Modules supported by steel podium



Developer Berkeley First chose modular construction for its key worker and starter homes project called Paragon in Brentford, West London because it achieved the short construction programme of 22 months and minimised logistical problems on site.

Sandwiched between the M4 motorway, suburban housing and a local school, the site presented major difficulties for access, delivery, storage of materials and site facilities for workers and equipment. Modular construction solved many of these problems, and modules were delivered at an average rate of 8 per day in a 40 minute turn a round without requiring road closure.

The use of modular construction is conventionally limited to 8 to 10 storeys, but the extension of the technology to 17 storeys in this project was achieved by a concrete core, which provided overall stability. In this way the modules are

required to resist vertical loading and to transfer wind loads to the core.

The first phases of the project were not originally conceived in modular construction, and for this reason the efficiencies of manufacture of repeatable modular units were not fully achieved. However, Caledonian Building Systems was able to manufacture a wide range of module types, many with open sides, so that two modules could be placed side by side to provide wider rooms.

The project comprises 6 buildings of 4, 5, 7, 12 and 17 storeys height. The total number of modules in the project is 827, and the 17 storey building consists of 413 modules. A typical module size is 12 m x 2.8 m, but some modules are manufactured up to 4.2 m wide, which is the maximum for motorway transport.

The project cost £26 million and was completed in September 2006.



Project Team

Developer:

Berkeley First

Architects:

Carey Jones

Structural Engineer:

**Capita Symonds,
Alan Wood and Partners**

Modular Contractor:

Caledonian Building Systems**Construction Details**

The Paragon project comprises 840 en suite student rooms, 114 en suite studio rooms, 44 one bedroom and 63 two-bedroom key worker apartments. Modules were combined to create larger apartments. The one or two bedroom apartments were constructed using 2 or 3 modules, each of 35.55 m² floor area.

The modules use light steel C sections in the floors and walls combined with Square or Rectangular Hollow Section posts, which resist the vertical loads. The posts were 80 x 80 SHS or 160 x 80 RHS in varying thicknesses depending on the building height. These posts fit within the light steel wall panels. The edge beams use 200 x 90 hot rolled Parallel Flange

Channels (PFC) at floor level and 140 x 70 PFC at ceiling level in order to design partially open sided modules of up to 6 m span. The combined floor and ceiling depth was 400 mm and the combined width of walls was 290 mm. Both constructions achieved an excellent airborne sound reduction of over 60 dB, and a fire resistance up to 120 minutes.

Modules are attached to each other and to the concrete core by steel angles fixed to channels cast into the concrete core. The forces in these connections were established by consideration of wind forces and structural integrity. Construction of the slip formed cores was completed in advance of the modules being installed. In some areas, the modules were installed on a steel-framed podium in order to allow vehicular access below to the basement level.



Modules attached to concrete core



Installation of module on steel podium

Social Housing in Evreux, France

A 4 storey residential building using a dry construction system led to fast track installation, flexibility in use and sustainability over its life.

Application Benefits:

- Fast track construction
- Intensive use of steel components using dry construction
- Lightweight construction and low foundation work
- Building can be re-configured in the future
- Flexibility in space use



This residential building was promoted by the Social Housing Agency and Public Development and Construction Service of Eure (OPAC de l'Eure) in cooperation with France's Ministry of Town Planning and Housing. The architects, Dubosc & Landowski, had been involved in the promotion of steel intensive use in building for many years, and proposed an innovative design concept for this 51 rental housing project, which included a district library.

The design was completely re-evaluated in favour of a steel-intensive dry construction approach with concrete limited to a minimum for basements and ground floor.

The project consisted of five 4 storey adjoining buildings, with 51 social housing flats ranging from 56 m² to 106 m², in two

to five room configurations plus a 328 m² district library on two levels. The upper flats had two levels with terraces and large openings. A total of 22 covered parking spaces were also part of the building.

The structure consisted of a primary steel frame, deep decking and floor boarding, a curved metal roof and external steel stairs and X bracing. The whole building system is lightweight and potentially extendable or demountable in the future.

The project was part of a series of urban renovation initiatives in Evreux, Normandy. The total building cost was 775 €/m² floor area, of which 20% of the cost was the steel structure, floors and roof. The building was completed in 9 months, mainly due to the prefabricated nature of the construction process.

Project Team

Developer:

OPAC de l'Eure

Architect:

Dubosc & Landowski

Design Office:

Bohic

Contractor:

Quille**Construction Details**

The structural frame was made from hot rolled steel sections. The bracing was a flat cross bar system, integrated in partition walls and in the slab's depth for horizontal bracing. This structural frame is expressed from many points of the building, both outdoor and indoor showing the radical approach of design.

The envelope is a combination of wooden panels and steel sheeting giving an architectural contrast in colours and texture. The roof is made from arched steel sheeting supported on purlins.

The floor is a dry mixed system called PCIS "Plancher Composite Interactif Sec" from ArcelorMittal made from a combination of profiled deep steel decking, mineral wool for sound and thermal insulation, plywood panels and a floating screed. The beams were integrated in the slab depth to 320 mm

and spanned up to 6 m for a live load of 1.5 kN/m² plus distributed load of 1 kN/m² (partitions and finishes).

All materials were all widely available and could be handled and installed by skilled workers in a fast track construction process. Large parts of the building elements were produced in the factory providing a high quality and fast track construction process.

A fire resistance of 30 minutes was achieved with two 13 mm plasterboards for the ceilings. Thermal and acoustic performances were better than required which led to the award of a quality label in France "EDF-Innov'elec".

Lightweight concrete was used in limited areas, mainly in the basement and ground floor. The use of lightweight concrete reduced the weight of the building and therefore the foundation sizes.



(Above) Mixed use of materials



(Right) Intermediate floor showing wide open space for flexible arrangement of partitions and intensive use of steel elements

La Fenêtre, The Hague

A novel construction system was used to create a 16-storey apartment building in the city centre of Den Haag, Netherlands. The steel superstructure is supported on inclined tubular legs and the building is designed to be 'transparent'.

Application Benefits:

- Stability provided by inclined tubular columns
- Transparent façade with shallow floor zone
- Exposed concrete slab with embedded water pipes
- Fire resistance of 120 minutes
- Under-floor services distribution
- Excellent acoustic insulation



An exciting steel structure, called La Fenêtre forms a landmark at a busy road inter-section in The Hague (Den Haag) close to Rotterdam. Its 16-storeys of apartments are supported on inclined tubular legs. It uses a novel structural system called *Slimline*, which is based on a series of I beams at 0.6 to 0.9 m spacing, in which a concrete slab is precast around the bottom flange of the beam. The coverage of the inverted precast slab is 2.4 m, which is suitable for transportation and installation.

The inverted slab is typically 70 mm thick and is exposed on its underside. Services are located on the slab and also provide for under-floor heating and cooling. The flooring attached to the top flange spans between the beams, and can use a gypsum screed placed on floor boarding or shallow decking.

The construction system may also be used for offices and hospitals where there is a need for under-floor distribution of services. In this building, water pipes were also embedded in the slab to provide heating, and the inverted slab is able to radiate heat or 'coolth' to the space.

The façade is fully glazed and with its 20 m long tubular legs, the building appears to be transparent. The structure is braced internally and also consists of strategically located tubular members.

Fire tests were carried out at TNO in Delft to justify 120 minutes fire resistance of the otherwise unprotected steel beams due to the thermal insulation provided by the inverted slab. Excellent acoustic insulation was also achieved.

Construction started in early 2004 and was completed in late 2005.

Project Team

Client:

Latei projectontwikkeling

Architect:

Architectenbureau Uytengaak

Steel structure:

Oostingh Staalbouw

Project Engineers:

Adams

Flooring Contractor:

PreFab Limburg BV

Services contractor:

Heijmans**Construction Details**

A variety of steel beams can be used in the *Slimline* system, depending on their span and loading. Although the top flange of the beam is not laterally restrained, torsional restraint is provided by the slab cast around the bottom flange. A typical beam span to depth ratio is 20, and so a 450 mm deep I beam can span up to 9 m.

Services were passed through elongated openings formed in the web of the beams, and a floor of minimum depth of 600 mm was created.

The inverted concrete slab was designed to support its own weight and loads from services, and was typically 70 mm thick. The floor comprised a gypsum screed poured on floor boarding or shallow (20 mm) decking and was 60-80 mm thick. The structure was designed to support the imposed floor loading of up to 3 kN/m².

The *Slimline* precast floor panels can be supported by perimeter steel beams placed below the floor panels. The slab is cast 100 mm short of the edge of the beams. The supporting beams align with internal separating walls. Heating/cooling pipes can also be cast into the slab, depending on the application, and radiate into the space below.

In La Fenêtre, the inclined tubular legs were located below column positions on a 6 m x 9 m grid and were brought down to 8 discrete positions at ground level to optimise foundation requirements. Fire protection costs were minimised by the thermal insulation provided by the inverted slab, and the use of tubular members with high massivity. The building was stabilised by the tubular columns with internal tubular bracing.



(Above) Building during construction



(Right) Under-floor servicing in Slimline

Bioclimatic Towers, Vitoria Gasteiz

The Bioclimatic Towers in the Salburua Fens, Vitoria-Spain, are 4 similar towers of apartments, commercial space and offices, using 1,400 tonnes of steel. Control of solar radiation was achieved through a bioclimatic design.

Application Benefits:

- Outstanding architectural solution
- Sustainable and energy efficient with a bioclimatic approach.
- Prefabrication of the structure.
- Maximum flexibility concerning the use of the space.
- Recyclability of the building structure.
- Intensive use of steel components



Bioclimatic Towers

(Left) View of the completed steel structure

Salburua is a wetland area of international importance, situated on the edge of the city, forming part of the Green Ring of Vitoria-Gasteiz. Four towers comprising offices and social housing were built in the outskirts of the city. Critical design criteria for the towers were sustainability, structural efficiency, long-term usability and maintenance.

All the apartments in the towers have two orientations. The towers are highly sustainable, due to their optimum orientations, the energy efficient façade and the integration of renewable energy systems.

They were exhibited in the Museum of Modern Art (MOMA) of New York. The project was designed by the prestigious architects, Iñaki Abalos and Juan Herreros. Each tower has a floor area of 281.5 m² per storey and is 48 m high.

The 16 storey Bioclimatic Towers were built with a perimeter steel structure, reinforced concrete floors and internal columns (only 4 steel columns per floor). The structure of all the towers consists of 1,400 tonnes of steel. The total budget for the project of four towers was approximately 2.35 Million Euro. The buildings were completed in 2006.



Bioclimatic Towers under construction

Project Team

Client:

Ensnache XXI

Architect:

Ábalos & Herreros

Owner:

Jaureguizahar S.L

Steel frames:

Goros Construcciones Metálicas

Contractors:

Goros S.Coop (Vitoria-Gasteiz)**Construction Details**

The structure was made with four prefabricated panels for every two storeys of the building (approximately 6 m high). The main steel structure was completely fabricated in the factory, making the assembly phase on site much faster and more efficient.

The reinforced concrete floor (using concrete grade 25) was a solid slab of 250 mm depth, which achieved maximum spans of 7 m and was built totally on site.

The columns had mixed steel and concrete sections based on the particular tower and the height of the building. The steel sections were made from HEM200 to HEM600 or from HEB180 to HEB500 in S355 grade steel. In the majority of the columns, cross-pieces of steel section of HEM120, each approximately 3 m span, were encased with

reinforced bars (steel B500S, 8 mm diameter at 200 mm spacing) and fixed into the concrete floor.

The structural panels were composed of plated girders of more than 1 m depth with variable spans in the perimeter of the towers from 2.3 to 2.9 m.

Welded connections were fabricated in the factory whereas on-site bolted connections were used because of their speed of installation and independence on the weather conditions.

A special transportation system was necessary to bring the prefabricated structural panels to site because they weighed more than 20 tonnes with a length of 30 m and width 6 m.

The structure was erected in record time, at an average rate of 1.5 days per floor. The time to fabricate and erect each tower was approximately 4 months, of which 2 months was manufacturing in the factory and 2 months assembly on site.

Acknowledgements:

To the company GOROS S.Coop. from Vitoria (Basque Country, www.goros.net) and especially to Miguel Angel Zudaire (Technical Director), the foreman Raúl Etayo, Pedro Marchan (Site Manager) and Mikel Zudaire.



Off-site fabrication of the façade structural panels



Floor with internal columns in the building works

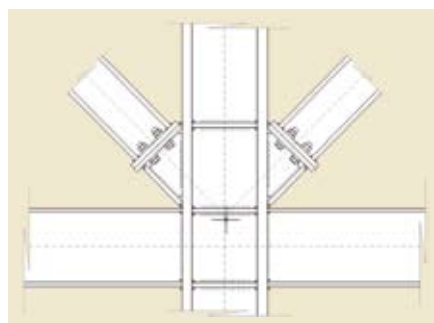

Bolted connection between columns on first floor and bracing

OpenHouse, Malmö

The aim of the OpenHouse system is to provide a cost-effective way to build apartments using modular construction. This project near Malmö provides 1200 apartments in a variety of plan forms.

Application Benefits:

- Adaptability in building use and form and future reuse of modules
- Sustainability by low materials use and wastage
- Risk minimizing and improved quality by industrialized processes, and dry construction on site
- Variety of cladding, roofing and balcony options
- High level of thermal and acoustic insulation



OpenHouse module during installation showing use of open sided modules with additional temporary posts



Annestad in Malmö, Sweden, is a large development by Swedish standards. A total of 1200 apartments were built during a period of four years. The development was divided into medium sized two to five storey blocks and completed in 2006. The development was a combination of rental apartments and tenant-ownership apartments. The rental cost of an apartment was approximately € 110 per m²/year.

The project used the OpenHouse system for the structural steel framing. The modules were based on a planning

grid of 3.9 m with length a multiple of 3.9 m. They had recessed corners and Square Hollow Section (SHS) corner posts.

The size of the apartments varied from one room plus kitchen to four rooms plus kitchen. Façade materials used in this project were a combination of bricks, boards, insulated render and wood. Modules were positioned in an off-set configuration to create a variable façade line. Metallic roofs, façades and balconies were added to the fully equipped modules on site.

Project Team

Client:

**Hyreshem Malmö /
OpenHouse Production**

Architect:

**Landskronagruppen /
OpenHouse Production**

Main Contractor:

OpenHouse Production

Supplier of Modules:

OpenHouse Production

*(Above) Module installation
and completed façades*

Construction Details

The modules were arranged within a framing system of SHS columns. The modules were supported by SHS columns at a spacing of 3.9 m. Each module was supported by six columns.

The internal dimensions of the modules were 3.6 m wide by up to 11 m long. The modules can cantilever 1.7 m from the exterior frame column. The typical finished weight of a module was 5 to 8 tonnes. The modules were constructed to transfer the horizontal loads to stabilising elements e.g. staircases using steel or concrete. The system can be used in eight storey buildings, although five storeys is the normal limit.

The modules used light steel framing in combination with mineral wool and gypsum boards. Exterior walls had

slotted light steel studs, mineral wool and gypsum boards, providing good thermal performance. The roof and floor of the module used light steel beams, mineral wool, gypsum board and trapezoidal steel sheets. The modules are self supporting against vertical and lateral loads up to five storeys high.

Slotted steel studs with mineral wool in between provide a high level of thermal insulation to achieve a U-value close to 0.1 W/m²K. Partially open sided modules were manufactured using intermediate posts, so that modules could be placed side by side to create larger room sizes.

Once lifted into position on site, the modules were connected to the SHS posts, the services linked up and flooring completed between open sided modules.



*(Right) The Annestad project near
Öresund, southern Sweden.*

**ArcelorMittal**

Long Carbon, Research and Development,
66, rue de Luxembourg, L - 4009 Esch/Alzette, Luxembourg
www.arcelormittal.com

**Bouwen met Staal**

Boerhaavelaan 40, NL - 2713 HX Zoetermeer,
Postbus 190, NL - 2700 AD Zoetermeer, The Netherlands
www.bouwenmetstaal.nl

**Centre Technique Industriel de la Construction Métallique (CTICM)**

Espace Technologique, L'orme des merisiers - Immeuble Apollo,
F - 91193 Saint-Aubin, France
www.cticm.com

**Forschungsvereinigung Stahlanwendung (FOSTA)**

Sohnstraße 65, D - 40237 Düsseldorf,
Germany
www.stahlforschung.de

**Labein - Tecnalia**

C/Geldo - Parque Tecnológico de Bizkaia - Edificio 700,
48160 Derio, Bizkaia, Spain
www.labein.es

**SBI**

Vasagatan 52, SE - 111 20 Stockholm,
Sweden
www.sbi.se

**The Steel Construction Institute (SCI)**

Silwood Park, Ascot, Berkshire,
SL5 7QN, United Kingdom
www.steel-sci.org

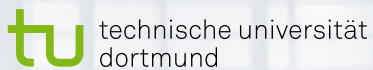
**Technische Universität Dortmund**

Fakultät Bauwesen - Lehrstuhl für Stahlbau
August-Schmidt-Strasse 6, D - 44227 Dortmund, Germany
www.uni-dortmund.de